

Next Generation Tools By



TCT
BAND SAW
BLADE

New Edge of Technology
DIAMOND
TECHNOLOGY

Awe-inspiring
Precision &
Performance

BRAZE - REPLACEABLE - PCD
Wood Working Tools

The Sign Of Excellence

Next Generation Tools By



The Company, Yash Tooling System is setting new Benchmarks in tools' designing, manufacturing and overall quality operations. With introduction of these tools with Replaceable Knives, Yash now has the distinction of being the first Indian company to undertake manufacturing of such international quality products. In the late nineties, Brazed tools market was teeming with various manufacturers, yash though being late entrant – acquired a position of premium brand very quickly. Still the quality brazed tools users always prefer Yash over any other product. Yash uses the best European machinery & processes to manufacture its products, with highest quality raw material. In short, Brazed or Replaceable, Yash tools are powered to give unbeatable performance and a long – long working life.

To win the markets, you have to do something extra – ordinary. Yash helps you achieve that. Your wood-work and panel jobs can be crafted so meticulously and consistently qualitatively that your product stand apart from the crowd, making you a winner of the customer choice. Yash Symbolises ultimate quality. Such highly dependable and systematically precision tools, till now were possible with imported brands only. Now you have it here in 'Yash', that too at comparably lower cost and with reliable supply and service support.

INNOVATIVE TOOLS FOR WOOD WORKING INDUSTRIES

Our In House Machine Facility

For

ENHANCE QUALITY | BETTER PERFORMANCE | UN BEATABLE PRICE
FASTEST DELIVERY | AFTER SALES & SERVICE



PCD Grinding



CNC Balancing Machine



Profile Grinding



CNC Profile Grinding



Induction Brazing



CNC Vertical Milling



CNC Turning

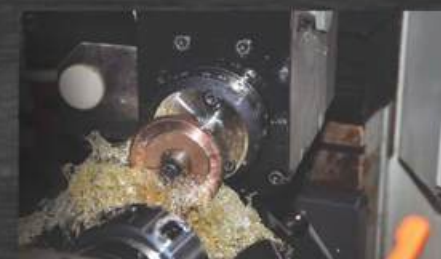

Two Flute Solid Carbide Spiral END MILL

Technical Details :

Use on CNC Router Machine

Application :

Use for Cutting, Grooving, Sizing, Nesting on CNC. 2 Flute Solid Carbide End Mill, High Performance Chip Board, Laminated Plywood, MDF, Melamine, Plastic etc..



YTS 01		Spiral Standard End Mill			
ORDER CODE	DIA	CUTTING LENGTH	TOTAL LENGTH	SHANK	
YTS 1 101	1	5	38	3	
YTS 1 102	1.5	6	38	3	
YTS 1 103	2	8	38	3	
YTS 1 104	3	15	38	3	
YTS 1 105	4	22	45	4	
YTS 1 106	5	22	50	5	
YTS 1 107	6	25	50	6	
YTS 1 108	8	25	60	8	
YTS 1 109	10	30	75	10	
YTS 1 110	12	30	75	12	
YTS 1 111	14	32	90	14	
YTS 1 112	16	45	100	16	



YTS 01		Spiral Long End Mill			
ORDER CODE	DIA	CUTTING LENGTH	TOTAL LENGTH	SHANK	
YTS 1 113	3	35	70	3	
YTS 1 114	4	35	70	4	
YTS 1 115	5	40	70	5	
YTS 1 116	6	32	60	6	
YTS 1 117	6	40	70	6	
YTS 1 118	8	40	75	8	



YTS 01		Spiral Extra Long End Mill			
ORDER CODE	DIA	CUTTING LENGTH	TOTAL LENGTH	SHANK	
YTS 1 119	3	50	100	3	
YTS 1 120	4	50	100	4	
YTS 1 121	5	50	100	5	
YTS 1 122	6	50	100	6	
YTS 1 123	6	75	100	6	
YTS 1 124	8	50	100	6	
YTS 1 125	8	75	150	8	
YTS 1 126	10	50	100	8	
YTS 1 127	10	75	150	10	
YTS 1 128	12	50	100	12	
YTS 1 129	12	75	150	12	

Four Flute Solid Carbide Spiral END MILL

Technical Details :

Use on CNC Router Machine

Application :

Use for Cutting, Grooving, Sizing, Nesting on CNC. 4 Flute Solid Carbide End Mill, High Performance Chip Board, Laminated Plywood, MDF, Melamine, Plastic etc..



YTS 02		Spiral Standard End Mill			
ORDER CODE	DIA	CUTTING LENGTH	TOTAL LENGTH	SHANK	
YTS 2 101	1	5	38	3	
YTS 2 102	1.5	6	38	3	
YTS 2 103	2	8	38	3	
YTS 2 104	3	15	38	3	
YTS 2 105	4	22	45	4	
YTS 2 106	5	22	50	5	
YTS 2 107	6	25	50	6	
YTS 2 108	8	25	60	8	
YTS 2 109	10	30	75	10	
YTS 2 110	12	30	75	12	
YTS 2 111	14	32	90	14	
YTS 2 112	16	45	100	16	

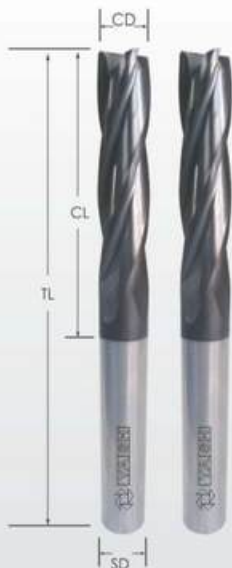

YTS 02		Spiral Long End Mill			
ORDER CODE	DIA	CUTTING LENGTH	TOTAL LENGTH	SHANK	
YTS 2 113	3	35	70	3	
YTS 2 114	4	35	70	4	
YTS 2 115	5	40	70	5	
YTS 2 116	6	32	60	6	
YTS 2 117	6	40	70	6	
YTS 2 118	8	40	75	8	



YTS 02		Spiral Extra Long End Mill			
ORDER CODE	DIA	CUTTING LENGTH	TOTAL LENGTH	SHANK	
YTS 2 119	3	50	100	3	
YTS 2 120	4	50	100	4	
YTS 2 121	5	50	100	5	
YTS 2 122	6	50	100	6	
YTS 2 123	6	75	100	6	
YTS 2 124	8	50	100	6	
YTS 2 125	8	75	150	8	
YTS 2 126	10	50	100	8	
YTS 2 127	10	75	150	10	
YTS 2 128	12	50	100	12	
YTS 2 129	12	75	150	12	



Two Flute Solid Carbide Spiral BALL NOSE



Technical Details :

Use on CNC Router Machine

Application :

used for efficient contour cutting, end-trimming and panel sizing on solid wood, wood composites, plastic materials and laminates at high feed speed. Ensure to properly clamp workpieces. Can be used on machining , point-to-point boring machines, CNC routers and hand-held routers equipped with chucks or adapters. Cost-effective solution with respect to brazed and spiral in tungsten carbide.

YTS 03		Spiral Standard Ball Nose		
ORDER CODE	DIA	CUTTING LENGTH	TOTAL LENGTH	SHANK
YTS 3 101	1	5	38	3
YTS 3 102	1.5	6	38	3
YTS 3 103	2	8	38	3
YTS 3 104	3	15	38	3
YTS 3 105	4	22	45	4
YTS 3 106	5	22	50	5
YTS 3 107	6	25	50	6
YTS 3 108	8	25	60	8
YTS 3 109	10	30	75	10
YTS 3 110	12	30	75	12
YTS 3 111	14	32	90	14
YTS 3 112	16	45	100	16

YTS 03		Spiral Long Ball Nose		
ORDER CODE	DIA	CUTTING LENGTH	TOTAL LENGTH	SHANK
YTS 3 113	3	35	70	3
YTS 3 114	4	35	70	4
YTS 3 115	5	40	70	5
YTS 3 116	6	32	60	6
YTS 3 117	6	40	70	6
YTS 3 118	8	40	75	8

YTS 03		Spiral Extra Long Ball Nose		
ORDER CODE	DIA	CUTTING LENGTH	TOTAL LENGTH	SHANK
YTS 3 119	3	50	100	3
YTS 3 120	4	50	100	4
YTS 3 121	5	50	100	5
YTS 3 122	6	50	100	6
YTS 3 123	6	75	100	6
YTS 3 124	8	50	100	6
YTS 3 125	8	75	150	8
YTS 3 126	10	50	100	10
YTS 3 127	10	75	150	10
YTS 3 128	12	50	100	12
YTS 3 129	12	75	150	12

Four Flute

Solid Carbide Spiral
BALL NOSE

Technical Details :

Use on CNC Router Machine

Application :

MDF,Solid Wood,3D Work MDF,Solid Wood,3D Work



YTS 04		Spiral Standard Ball Nose			
ORDER CODE	DIA	CUTTING LENGTH	TOTAL LENGTH	SHANK	
YTS 4 101	1	5	38	3	
YTS 4 102	1.5	6	38	3	
YTS 4 103	2	8	38	3	
YTS 4 104	3	15	38	3	
YTS 4 105	4	22	45	4	
YTS 4 106	5	22	50	5	
YTS 4 107	6	25	50	6	
YTS 4 108	8	25	60	8	
YTS 4 109	10	30	75	10	
YTS 4 110	12	30	75	12	
YTS 4 111	14	32	90	14	
YTS 4 112	16	45	100	16	



YTS 04		Spiral Long Ball Nose			
ORDER CODE	DIA	CUTTING LENGTH	TOTAL LENGTH	SHANK	
YTS 4 113	3	35	70	3	
YTS 4 114	4	35	70	4	
YTS 4 115	5	40	70	5	
YTS 4 116	6	32	60	6	
YTS 4 117	6	40	70	6	
YTS 4 118	8	40	75	8	



YTS 04		Spiral Extra Long Ball Nose			
ORDER CODE	DIA	CUTTING LENGTH	TOTAL LENGTH	SHANK	
YTS 4 119	3	50	100	3	
YTS 4 120	4	50	100	4	
YTS 4 121	5	50	100	5	
YTS 4 122	6	50	100	6	
YTS 4 123	6	75	100	6	
YTS 4 124	8	50	100	6	
YTS 4 125	8	75	150	8	
YTS 4 126	10	50	100	10	
YTS 4 127	10	75	150	10	
YTS 4 128	12	50	100	12	
YTS 4 129	12	75	150	12	



Single Flute

Solid Carbide Spiral
END MILL

Technical Details :

Use on CNC Router Machine

Application :

used for efficient contour cutting, end-trimming and panel sizing on solid wood, wood composites, plastic materials and laminates at high feed speed. Ensure to properly clamp workpieces.

Single Flute Solid Carbide Spiral End Mill - YTS 5 (Standard Length)



YTS 05		Spiral Standard Length		
ORDER CODE	DIA	CUTTING LENGTH	TOTAL LENGTH	SHANK
YTS 5 101	1	6	38	3
YTS 5 102	2	8	38	3
YTS 5 103	3	15	38	3
YTS 5 104	4	22	45	4
YTS 5 105	5	22	50	5
YTS 5 106	6	25	50	6
YTS 5 107	8	30	60	8
YTS 5 108	10	30	70	10
YTS 5 109	12	30	75	12

YTS 05		Spiral Long Length		
ORDER CODE	DIA	CUTTING LENGTH	TOTAL LENGTH	SHANK
YTS 5 110	6	35	70	6
YTS 5 111	8	40	75	8
YTS 5 112	6	50	100	6
YTS 5 113	8	50	100	8
YTS 5 114	10	50	100	10

Single Flute Solid Carbide Spiral End Mill For Aluminum - YTS 6



SINGLE FLUTE ENDMILL FOR ALUMINUM

YTS 06				
ORDER CODE	DIA	CUTTING LENGTH	TOTAL LENGTH	SHANK
YTS 6 101	2	8	38	3
YTS 6 102	3	15	38	3
YTS 6 103	4	18	45	4
YTS 6 104	6	25	50	6
YTS 6 105	8	30	60	8

Single Flute Solid Carbide Spiral End Mill For Down Cut - YTS 7



SINGLE FLUTE ENDMILL FOR DOWN CUT

YTS 07				
ORDER CODE	DIA	CUTTING LENGTH	TOTAL LENGTH	SHANK
YTS 7 101	3	15	38	3
YTS 7 102	4	22	45	4
YTS 7 103	6	25	50	6
YTS 7 104	8	30	60	8

Technical Details :

Use on CNC Router Machine

Application :

used for efficient contour cutting, end-trimming and panel sizing on solid wood, wood composites, plastic materials and laminates at high feed speed. Ensure to properly clamp workpieces.

Two Flute Solid Carbide Spiral SPIRAL END MILL

Two Flute Solid Carbide Spiral End Mill For Down Cut - YTS 8



TWO FLUTE ENDMILL FOR DOWN CUT

YTS 08				
ORDER CODE	DIA	CUTTING LENGTH	TOTAL LENGTH	SHANK
YTS 8 101	3	15	38	3
YTS 8 102	4	22	45	4
YTS 8 103	5	22	50	5
YTS 8 104	6	25	50	6
YTS 8 105	8	30	60	8
YTS 8 106	10	30	75	10
YTS 8 107	12	30	75	8

Two Flute Solid Carbide Spiral End Mill For Up - Down Cut - YTS 9



TWO FLUTE ENDMILL FOR

UP-DOWN CUT

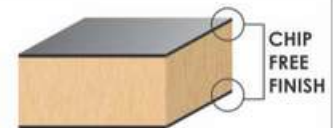

YTS 09				
ORDER CODE	DIA	CUTTING LENGTH	TOTAL LENGTH	SHANK
YTS 9 101	4	20	50	4
YTS 9 102	6	25	50	6
YTS 9 103	8	30	60	8
YTS 9 104	10	30	75	10
YTS 9 105	12	30	75	12

Singel Flute HSS Spiral End Mill - YTS 10



SINGLE FLUTE HSS ENDMILL

YTS 10				
ORDER CODE	DIA	CUTTING LENGTH	TOTAL LENGTH	SHANK
YTS 10 101	3	12	60	60
YTS 10 102	4	12	60	60
YTS 10 103	5	14	80	60
YTS 10 104	5	14	100	100
YTS 10 105	6	14	80	80
YTS 10 106	6	15	100	100
YTS 10 107	8	14	80	80
YTS 10 108	8	14	120	120
YTS 10 109	10	14	80	80



Solid Carbide

TAPER BALL NOSE

Technical Details :

Use on CNC Router Machine

Application :

2D and 3D contouring, profiling, modeling and pattern making for cabinetry, sign making, furniture making and jewelry mold makin

Solid Carbide Taper Ball Nose Straight - YTS 11



Solid Carbide **STRAIGHT TAPER BALL NOSE**

YTS 11				
ORDER CODE	DIA	CUTTING LENGTH	TOTAL LENGTH	SHANK
YTS 11 101	2	25	50	6
YTS 11 102	3	25	50	6
YTS 11 103	4	25	50	6
YTS 11 104	3	35	70	6
YTS 11 105	4	35	70	6

Solid Carbide Spiral Taper Ball Nose - YTS 12



Solid Carbide **SPIRAL TAPER BALL NOSE**

YTS 12 STANDARD LENGTH				
ORDER CODE	DIA	CUTTING LENGTH	TOTAL LENGTH	SHANK
YTS 12 101	1	25	50	6
YTS 12 102	1.5	25	50	6
YTS 12 103	2	25	50	6
YTS 12 104	3	25	50	6
YTS 12 105	4	25	50	6

YTS 12 LONG LENGTH				
ORDER CODE	DIA	CUTTING LENGTH	TOTAL LENGTH	SHANK
YTS 12 106	1	35	70	6
YTS 12 107	1.5	35	70	6
YTS 12 108	2	35	70	6
YTS 12 109	3	35	70	6
YTS 12 110	4	35	70	6
YTS 12 111	1	35	70	8
YTS 12 112	2	35	70	8
YTS 12 113	3	35	70	8
YTS 12 114	4	35	70	8
YTS 12 115	6	35	70	8

YTS 12 EXTRA LONG				
ORDER CODE	DIA	CUTTING LENGTH	TOTAL LENGTH	SHANK
YTS 12 118	2	50	100	6
YTS 12 119	3	50	100	6
YTS 12 120	4	50	100	6
YTS 12 121	2	50	100	8
YTS 12 122	3	50	100	8
YTS 12 123	4	50	100	8
YTS 12 124	6	50	100	8

Solid Carbide
Ruffer for Nesting

Technical Details :

Use on CNC Router Machine

Application :

The unique design contributes to superb performance and excellent cutting results for use on CNC routers for jointing, rabbeting, grooving, on laminates, MDF, HPL, veneer and melamine-faced panels. High performance pre-finishing and finish-routing

Solid Carbide Nesting Bit 3 Flute - YTS 13



Solid Carbide
**NESTING BIT
3 FLUTE**

YTS 13			
ORDER CODE	DIA	CUTTING LENGTH	SHANK
YTS 13 101	4	20	8
YTS 13 102	5	20	12
YTS 13 103	6	25	12
YTS 13 104	6	28	12
YTS 13 105	8	25	12
YTS 13 106	8	30	12
YTS 13 107	10	30	12

Four Flute Solid Carbide Spiral Bit For Door Lock - YTS 14 (Racker)



Solid Carbide Spiral Bit for
**DOOR LOCK
4 FLUTE**

YTS 14				
ORDER CODE	DIA	CUTTING LENGTH	TOTAL LENGTH	SHANK
YTS 14 101	6	25	50	6
YTS 14 102	8	25	60	8
YTS 14 103	10	30	75	10
YTS 14 104	12	30	75	12

Solid Carbide Spiral Bit For Door Lock - YTS 15 (Racker)



Solid Carbide Spiral Bit for
**DOOR LOCK
RACKER**

YTS 15				
ORDER CODE	DIA	CUTTING LENGTH	TOTAL LENGTH	SHANK
YTS 15 101	12	55 (105)	165	12
YTS 15 102	14	55 (105)	165	14
YTS 15 103	16	55 (105)	165	16
YTS 15 104	18	55 (105)	165	18



Four Flute Solid Carbide Spiral End Mill - YTS 16



USE ON
HARDWOOD
ALUMINUM

YTS 16				
ORDER CODE	DIA	CUTTING LENGTH	TOTAL LENGTH	SHANK
YTS 16 101	2	6	50	3
YTS 16 102	3	9	50	3
YTS 16 103	4	12	50	4
YTS 16 104	5	15	50	5
YTS 16 105	6	18	50	6
YTS 16 106	8	25	60	8
YTS 16 107	10	25	75	10
YTS 16 108	12	30	75	12

Corn Bit Use for Cement Sheet - YTS 17



Corn Bit for
Cement Sheet

YTS 17				
ORDER CODE	DIA	CUTTING LENGTH	TOTAL LENGTH	SHANK
YTS 17 101	2	8	38	3
YTS 17 102	3	15	38	3
YTS 17 103	4	20	50	4
YTS 17 104	5	22	50	5
YTS 17 105	6	25	50	6

Solid Carbide Jewellery Bit - YTS 18 (Pentograph Half Cut)



Solid Carbide
Jewellery Bit

YTS 18				
ORDER CODE	DIA	DEGREE	TOTAL LENGTH	SHANK
YTS 18 101	3	40	38	3
YTS 18 102	4	60	45	3
YTS 18 103	6	40	50	4
YTS 18 104	6	60	50	5
YTS 18 105	6	90	50	6
YTS 18 106	8	60	50	8

Solid Carbide Engraving Bit - YTS 19



Solid Carbide
Engraving Bit

YTS 19				
ORDER CODE	DIA	CUTTING LENGTH	TOTAL LENGTH	SHANK
YTS 19 101	6	25	50	6
YTS 19 102	6	35	70	6
YTS 19 103	6	50	100	6

Solid Carbide 45° Carving Bit - YTS 20



Solid Carbide
45° Carving Bit

YTS 20				
ORDER CODE	DIA	DEGREE	TOTAL LENGTH	SHANK
YTS 20 101	2	45	38	3
YTS 20 102	3	45	38	3
YTS 20 103	4	45	45	4
YTS 20 104	5	45	50	5
YTS 20 105	6	45	50	6
YTS 20 106	8	45	60	8

Solid Carbide
STRAIGHT BIT

Technical Details :

Use on CNC Router Machine

Application :

Special positively ground cutting edge sharpening for excellent finish.

Solid Carbide Straight Bit - YTS 21



YTS 21		STANDARD LENGTH		
ORDER CODE	DIA	CUTTING LENGTH	TOTAL LENGTH	SHANK
YTS 21 101	2	8	38	3
YTS 21 102	3	15	38	3
YTS 21 103	4	22	45	4
YTS 21 104	4	25	50	4
YTS 21 105	5	22	50	5
YTS 21 106	6	25	50	6
YTS 21 107	6	32	60	8
YTS 21 108	8	30	60	8
YTS 21 109	10	30	70	10
YTS 21 110	12	30	75	12

YTS 21		LONG LENGTH		
ORDER CODE	DIA	CUTTING LENGTH	TOTAL LENGTH	SHANK
YTS 21 111	6	40	70	6
YTS 21 112	6	50	100	6
YTS 21 113	8	40	80	8
YTS 21 114	8	50	100	8
YTS 21 115	10	50	100	10
YTS 21 116	12	50	100	12

Solid Carbide Straight Bit - YTS 22



YTS 22		STANDARD LENGTH		
ORDER CODE	DIA	CUTTING LENGTH	TOTAL LENGTH	SHANK
YTS 22 101	2	8	50	6
YTS 22 102	3	15	50	6
YTS 22 103	4	20	50	6
YTS 22 104	4	25	50	6
YTS 22 105	5	22	50	6
YTS 22 106	4	25	60	8
YTS 22 107	5	25	60	8
YTS 22 108	6	25	60	8

Solid Carbide Straight Ball None - YTS 23



YTS 23				
ORDER CODE	DIA	CUTTING LENGTH	TOTAL LENGTH	SHANK
YTS 23 101	4	22	45	4
YTS 23 102	5	22	50	5
YTS 23 103	6	25	50	6
YTS 23 104	8	30	60	8

Solid Carbide Straight Bit Steel Shank - YTS 24



YTS 24			
ORDER CODE	DIA	CUTTING LENGTH	SHANK
YTS 24 101	2	8	6
YTS 24 102	2	8	6.35
YTS 24 103	2	8	8
YTS 24 104	3	12	6
YTS 24 105	3	12	6.35
YTS 24 106	3	12	8
YTS 24 107	4	15	6
YTS 24 108	4	15	6.35
YTS 24 109	4	15	8
YTS 24 110	6	15	8
YTS 24 111	6	25	8

Solid Carbide Straight Bit Steel Shank - YTS 25



YTS 25			
ORDER CODE	DIA	CUTTING LENGTH	SHANK
YTS 25 101	3	15	12
YTS 25 102	4	15	12
YTS 25 103	5	20	12
YTS 25 104	6	20	12
YTS 25 105	8	25	12
YTS 25 106	10	30	12

Solid Carbide Jobber Drill Bits - YTS 26



**Solid Carbide
Jobber Drill**
Use for Hand Drill

YTS 26			
ORDER CODE	DIA	CUTTING LENGTH	TOTAL LENGTH
YTS 26 101	4	43	75
YTS 26 102	5	52	86
YTS 26 103	6	57	93
YTS 26 104	7	69	109
YTS 26 105	8	75	117
YTS 26 106	9	81	125
YTS 26 107	10	87	133
YTS 26 108	11	94	142
YTS 26 109	12	101	151



Technical Details :

Use on CNC Router Machine

Application :

Special positively ground cutting edge sharpening for excellent finish.

YTB 114				
ORDER CODE	DIA	CUTTING LENGTH	SHANK	Z
YTB 114 101	6	20	6	2
YTB 114 102	6	20	6.35	2
YTB 114 103	6	20	8	2
YTB 114 104	8	25	12	2
YTB 114 105	8	30	8	2
YTB 114 106	8	30	12	2
YTB 114 107	9	30	12	2
YTB 114 108	10	30	8	2
YTB 114 109	10	30	12	2
YTB 114 110	11	30	12	2
YTB 114 111	12	30	12	2
YTB 114 112	12	35	12	2
YTB 114 113	12	40	12	2
YTB 114 114	12	50	12	2
YTB 114 115	16	40	12	2
YTB 114 116	18	40	12	2
YTB 114 117	20	40	12	2

KIWI EDGE Trimming Bit TCT (Brazed) - YTB 115

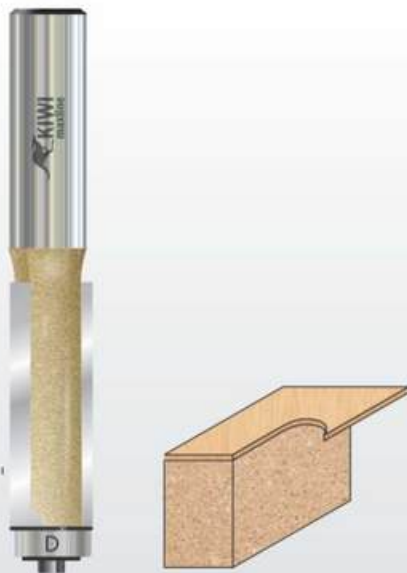

Technical Details :

Use on CNC Router Machine

Application :

Special positively ground cutting edge sharpening for excellent finish.

YTB 115				
ORDER CODE	DIA	CUTTING LENGTH	SHANK	Z
YTB 115 101	6.35	20	6	2
YTB 115 102	6.35	20	6.35	2
YTB 115 103	9.52	25	6	2
YTB 115 104	9.52	25	6.35	2
YTB 115 105	9.52	25	8	2
YTB 115 106	9.52	30	8	2
YTB 115 107	12.7	38	8	2
YTB 115 108	12.7	38	12	2
YTB 115 109	12.7	50	12.7	2

KIWI EDGE Radius Bit TCT (Brazed) - YTB 116



YTB 116			
ORDER CODE	RADIUS	SHANK	Z
YTB 116 101	2 R	6	2
YTB 116 102	2 R	6.35	2
YTB 116 103	2 R	8	2
YTB 116 104	3 R	6	2
YTB 116 105	3 R	6.35	2
YTB 116 106	3 R	8	2



Technical Details :

Use on Multi Boring Machine

Application :

Used to drill blind holes in solid wood, wood composites, plastic and laminated materials.

YTB 117

ORDER CODE	DIA	TOTAL LENGTH	SHANK
YTB 117 101 RH	3	57	10
YTB 117 101 LH	3	57	10
YTB 117 102 RH	4	57	10
YTB 117 102 LH	4	57	10
YTB 117 103 RH	5	57	10
YTB 117 103 LH	5	57	10
YTB 117 104 RH	6	57	10
YTB 117 104 LH	6	57	10
YTB 117 105 RH	7	57	10
YTB 117 105 LH	7	57	10
YTB 117 106 RH	8	57	10
YTB 117 106 LH	8	57	10
YTB 117 107 RH	9	57	10
YTB 117 107 LH	9	57	10
YTB 117 108 RH	10	57	10
YTB 117 108 LH	10	57	10
YTB 117 109 RH	11	57	10
YTB 117 109 LH	11	57	10
YTB 117 110 RH	12	57	10
YTB 117 110 LH	12	57	10
YTB 117 111 RH	15	57	10
YTB 117 111 LH	15	57	10

KIWI Multi Boring Bit - YTB 118



Technical Details :

Use on Multi Boring Machine

Application :

Used to drill blind holes in solid wood, wood composites, plastic and laminated materials.

YTB 118

ORDER CODE	DIA	TOTAL LENGTH	SHANK
YTB 118 101 RH	3	70	10
YTB 118 101 LH	3	70	10
YTB 118 102 RH	4	70	10
YTB 118 102 LH	4	70	10
YTB 118 103 RH	5	70	10
YTB 118 103 LH	5	70	10
YTB 118 104 RH	6	70	10
YTB 118 104 LH	6	70	10
YTB 118 105 RH	7	70	10
YTB 118 105 LH	7	70	10
YTB 118 106 RH	8	70	10
YTB 118 106 LH	8	70	10
YTB 118 107 RH	9	70	10
YTB 118 107 LH	9	70	10
YTB 118 108 RH	10	70	10
YTB 118 108 LH	10	70	10
YTB 118 109 RH	11	70	10
YTB 118 109 LH	11	70	10
YTB 118 110 RH	12	70	10
YTB 118 110 LH	12	70	10
YTB 118 111 RH	15	70	10
YTB 118 111 LH	15	70	10



YTB 119

ORDER CODE	DIA	TOTAL LENGTH	SHANK
YTB 119 101 RH	15	57	10
YTB 119 101 LH	15	57	10
YTB 119 102 RH	18	57	10
YTB 119 102 LH	18	57	10
YTB 119 103 RH	20	57	10
YTB 119 103 LH	20	57	10
YTB 119 104 RH	22	57	10
YTB 119 104 LH	22	57	10
YTB 119 105 RH	25	57	10
YTB 119 105 LH	25	57	10
YTB 119 106 RH	30	57	10
YTB 119 106 LH	30	57	10
YTB 119 107 RH	35	57	10
YTB 119 107 LH	35	57	10
YTB 119 108 RH	40	57	10
YTB 119 108 LH	40	57	10
YTB 119 109 RH	63.5	57	10
YTB 119 109 LH	63.5	57	10

Technical Details :

Use on Multi Boring Machine

Application :

Used to drill blind holes in solid wood, wood composites, plastic and laminated materials.

KIWI Hinge Boring Bit - YTB 120



YTB 120

ORDER CODE	DIA	TOTAL LENGTH	SHANK
YTB 120 101 RH	15	70	10
YTB 120 101 LH	15	70	10
YTB 120 102 RH	18	70	10
YTB 120 102 LH	18	70	10
YTB 120 103 RH	20	70	10
YTB 120 103 LH	20	70	10
YTB 120 104 RH	22	70	10
YTB 120 104 LH	22	70	10
YTB 120 105 RH	25	70	10
YTB 120 105 LH	25	70	10
YTB 120 106 RH	30	70	10
YTB 120 106 LH	30	70	10
YTB 120 107 RH	35	70	10
YTB 120 107 LH	35	70	10
YTB 120 108 RH	40	70	10
YTB 120 108 LH	40	70	10
YTB 120 109 RH	63.5	70	10
YTB 120 109 LH	63.5	70	10

Technical Details :

Use on Multi Boring Machine

Application :

Used to drill blind holes in solid wood, wood composites, plastic and laminated materials.





YTB 121		Extra Long	
ORDER CODE	DIA	TOTAL LENGTH	SHANK
YTB 121 101 RH	8	110	10
YTB 121 101 LH	8	110	10
YTB 121 102 RH	10	110	10
YTB 121 102 LH	10	110	10
YTB 121 103 RH	12	110	10
YTB 121 103 LH	12	110	10
YTB 121 104 RH	15	110	10
YTB 121 104 LH	15	110	10

KIWI Through Hole Boring Bit - YTB 122



YTB 122		DIA	TOTAL LENGTH	SHANK
ORDER CODE	DIA	TOTAL LENGTH	SHANK	SHANK
YTB 122 101 RH	3	57	10	
YTB 122 101 LH	3	57	10	
YTB 122 102 RH	4	57	10	
YTB 122 102 LH	4	57	10	
YTB 122 103 RH	5	57	10	
YTB 122 103 LH	5	57	10	
YTB 122 104 RH	6	57	10	
YTB 122 104 LH	6	57	10	
YTB 122 105 RH	7	57	10	
YTB 122 105 LH	7	57	10	
YTB 122 106 RH	8	57	10	
YTB 122 106 LH	8	57	10	
YTB 122 107 RH	10	57	10	
YTB 122 107 LH	10	57	10	
YTB 122 108 RH	12	57	10	
YTB 122 108 LH	12	57	10	

KIWI Through Hole Boring Bit - YTB 123



YTB 123		DIA	TOTAL LENGTH	SHANK
ORDER CODE	DIA	TOTAL LENGTH	SHANK	SHANK
YTB 123 101 RH	3	70	10	
YTB 123 101 LH	3	70	10	
YTB 123 102 RH	4	70	10	
YTB 123 102 LH	4	70	10	
YTB 123 103 RH	5	70	10	
YTB 123 103 LH	5	70	10	
YTB 123 104 RH	6	70	10	
YTB 123 104 LH	6	70	10	
YTB 123 105 RH	7	70	10	
YTB 123 105 LH	7	70	10	
YTB 123 106 RH	8	70	10	
YTB 123 106 LH	8	70	10	
YTB 123 107 RH	10	70	10	
YTB 123 107 LH	10	70	10	
YTB 123 108 RH	12	70	10	
YTB 123 108 LH	12	70	10	

LEFT RIGHT

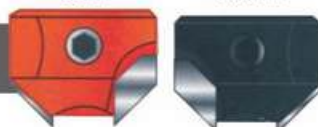

T.C.T. Counter Shank



Technical Details :

Use on Multi Boring Machine

Application :

Used to drill blind holes in solid wood, wood composites, plastic and laminated materials.

Pro Series

YTB 124	ORDER CODE	DIA	TOTAL LENGTH	SHANK
	YTB 124 101 RH	3	57	10
	YTB 124 101 LH	3	57	10
	YTB 124 102 RH	4	57	10
	YTB 124 102 LH	4	57	10
	YTB 124 103 RH	5	57	10
	YTB 124 103 LH	5	57	10
	YTB 124 104 RH	6	57	10
	YTB 124 104 LH	6	57	10
	YTB 124 105 RH	7	57	10
	YTB 124 105 LH	7	57	10
	YTB 124 106 RH	8	57	10
	YTB 124 106 LH	8	57	10
	YTB 124 107 RH	9	57	10
	YTB 124 107 LH	9	57	10
	YTB 124 108 RH	10	57	10
	YTB 124 108 LH	10	57	10
	YTB 124 109 RH	11	57	10
	YTB 124 109 LH	11	57	10
	YTB 124 110 RH	12	57	10
	YTB 124 110 LH	12	57	10
	YTB 124 111 RH	15	57	10
	YTB 124 111 LH	15	57	10

Pro Series Multi Boring Bit - YTB 125



Technical Details :

Use on Multi Boring Machine

Application :

Used to drill blind holes in solid wood, wood composites, plastic and laminated materials.

Pro Series

YTB 125	ORDER CODE	DIA	TOTAL LENGTH	SHANK
	YTB 125 101 RH	3	70	10
	YTB 125 101 LH	3	70	10
	YTB 125 102 RH	4	70	10
	YTB 125 102 LH	4	70	10
	YTB 125 103 RH	5	70	10
	YTB 125 103 LH	5	70	10
	YTB 125 104 RH	6	70	10
	YTB 125 104 LH	6	70	10
	YTB 125 105 RH	7	70	10
	YTB 125 105 LH	7	70	10
	YTB 125 106 RH	8	70	10
	YTB 125 106 LH	8	70	10
	YTB 125 107 RH	9	70	10
	YTB 125 107 LH	9	70	10
	YTB 125 108 RH	10	70	10
	YTB 125 108 LH	10	70	10
	YTB 125 109 RH	11	70	10
	YTB 125 109 LH	11	70	10
	YTB 125 110 RH	12	70	10
	YTB 125 110 LH	12	70	10
	YTB 125 111 RH	15	70	10
	YTB 125 111 LH	15	70	10



Technical Details :

Use on Multi Boring Machine

Application :

Used to drill blind holes in solid wood, wood composites, plastic and laminated materials.

Pro Series

YTB 126		DIA	TOTAL LENGTH	SHANK
ORDER CODE				
YTB 126 101 RH		15	57	10
YTB 126 101 LH		15	57	10
YTB 126 102 RH		18	57	10
YTB 126 102 LH		18	57	10
YTB 126 103 RH		20	57	10
YTB 126 103 LH		20	57	10
YTB 126 104 RH		22	57	10
YTB 126 104 LH		22	57	10
YTB 126 105 RH		25	57	10
YTB 126 105 LH		25	57	10
YTB 126 106 RH		30	57	10
YTB 126 106 LH		30	57	10
YTB 126 107 RH		35	57	10
YTB 126 107 LH		35	57	10
YTB 126 108 RH		40	57	10
YTB 126 108 LH		40	57	10
YTB 126 109 RH		63.5	57	10
YTB 126 109 LH		63.5	57	10



Technical Details :

Use on Multi Boring Machine

Application :

Used to drill blind holes in solid wood, wood composites, plastic and laminated materials.

Pro Series

YTB 127		DIA	TOTAL LENGTH	SHANK
ORDER CODE				
YTB 127 101 RH		15	70	10
YTB 127 101 LH		15	70	10
YTB 127 102 RH		18	70	10
YTB 127 102 LH		18	70	10
YTB 127 103 RH		20	70	10
YTB 127 103 LH		20	70	10
YTB 127 104 RH		22	70	10
YTB 127 104 LH		22	70	10
YTB 127 105 RH		25	70	10
YTB 127 105 LH		25	70	10
YTB 127 106 RH		30	70	10
YTB 127 106 LH		30	70	10
YTB 127 107 RH		35	70	10
YTB 127 107 LH		35	70	10
YTB 127 108 RH		40	70	10
YTB 127 108 LH		40	70	10
YTB 127 109 RH		63.5	70	10
YTB 127 109 LH		63.5	70	10



YTB 128		Pro Series	
ORDER CODE	DIA	TOTAL LENGTH	SHANK
YTB 128 101 RH	8	110	10
YTB 128 101 LH	8	110	10
YTB 128 102 RH	10	110	10
YTB 128 102 LH	10	110	10
YTB 128 103 RH	12	110	10
YTB 128 103 LH	12	110	10
YTB 128 104 RH	15	110	10
YTB 128 104 LH	15	110	10

Pro Series Through Hole Boring Bit - YTB 129



YTB 129		Pro Series	
ORDER CODE	DIA	TOTAL LENGTH	SHANK
YTB 129 101 RH	3	57	10
YTB 129 101 LH	3	57	10
YTB 129 102 RH	4	57	10
YTB 129 102 LH	4	57	10
YTB 129 103 RH	5	57	10
YTB 129 103 LH	5	57	10
YTB 129 104 RH	6	57	10
YTB 129 104 LH	6	57	10
YTB 129 105 RH	7	57	10
YTB 129 105 LH	7	57	10
YTB 129 106 RH	8	57	10
YTB 129 106 LH	8	57	10
YTB 129 107 RH	10	57	10
YTB 129 107 LH	10	57	10
YTB 129 108 RH	12	57	10
YTB 129 108 LH	12	57	10

Pro Series Through Hole Boring Bit - YTB 130



YTB 130		Pro Series	
ORDER CODE	DIA	TOTAL LENGTH	SHANK
YTB 130 101 RH	3	70	10
YTB 130 101 LH	3	70	10
YTB 130 102 RH	4	70	10
YTB 130 102 LH	4	70	10
YTB 130 103 RH	5	70	10
YTB 130 103 LH	5	70	10
YTB 130 104 RH	6	70	10
YTB 130 104 LH	6	70	10
YTB 130 105 RH	7	70	10
YTB 130 105 LH	7	70	10
YTB 130 106 RH	8	70	10
YTB 130 106 LH	8	70	10
YTB 130 107 RH	10	70	10
YTB 130 107 LH	10	70	10
YTB 130 108 RH	12	70	10
YTB 130 108 LH	12	70	10





YTB 130A

ORDER CODE	DIA	MOULDING SIZE
YTB-130A 101	45	22-24
YTB-130A 102	45	22-24
YTB-130A 103	45	22-24
YTB-130A 104	45	22-24
YTB-130A 105	45	22-24
YTB-130A 106	45	22-24

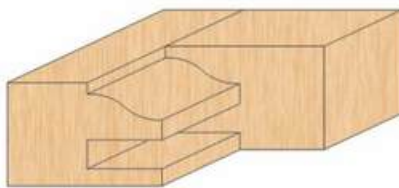
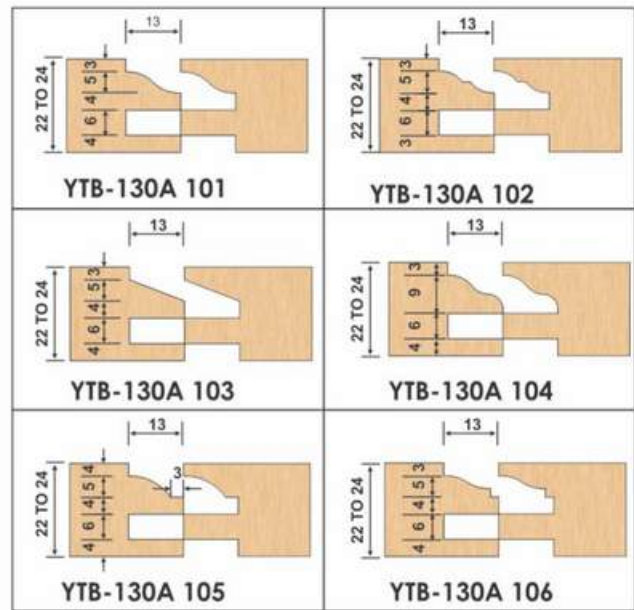

Half Radius Bit YTB-130B

*Shank size of this Router bits is 12 mm



YTB 130B

ORDER CODE	RADIUS	WOOD THICK
YTB-130B 101	6R	12
YTB-130B 102	8R	16
YTB-130B 103	10R	20
YTB-130B 104	12.5R	25
YTB-130B 105	15R	30
YTB-130B 106	19R	38
YTB-130B 107	22.5R	45
YTB-130B 108	25R	50

Classical Designs For Membrane Router Bit - YTB 131

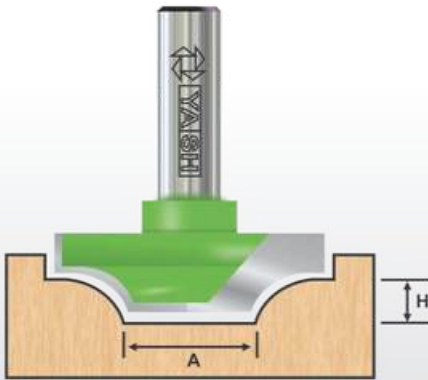

YTB 131				
ORDER CODE	DIA	A (mm)	DEPTH (H)	SHANK
YTB 131 101	12	5	1 / 1.5 / 2 / 2.5	12
YTB 131 102	15	5	1 / 1.5 / 2 / 2.5	12
YTB 131 103	25	10	1 / 1.5 / 2 / 2.5	12
YTB 131 104	28	13	1 / 1.5 / 2 / 2.5	12
YTB 131 105	30	14	1 / 1.5 / 2 / 2.5	12
YTB 131 106	32	15	1 / 1.5 / 2 / 2.5	12
YTB 131 107	35	17	1 / 1.5 / 2 / 2.5	12
YTB 131 108	38	18	1 / 1.5 / 2 / 2.5	12
YTB 131 109	40	20	1 / 1.5 / 2 / 2.5	12

Plung ogee For Membrane Router Bit - YTB 132

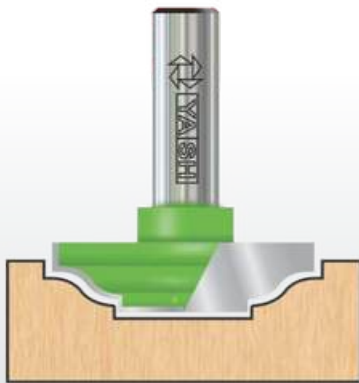

YTB 132				
ORDER CODE	DIA	A (mm)	DEPTH (H)	SHANK
YTB 132 101	25	10	2 / 2.5 / 3 / 4	12
YTB 132 102	28	13	2 / 2.5 / 3 / 4	12
YTB 132 103	30	14	2 / 2.5 / 3 / 4	12
YTB 132 104	32	15	2 / 2.5 / 3 / 4	12
YTB 132 105	35	17	2 / 2.5 / 3 / 4	12
YTB 132 106	38	18	2 / 2.5 / 3 / 4	12
YTB 132 107	40	20	2 / 2.5 / 3 / 4	12

Round Nose Membrane Router Bit - YTB 133

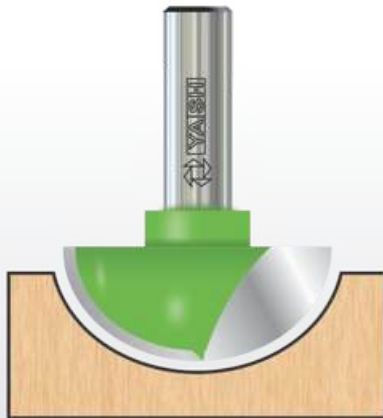

YTB 133			
ORDER CODE	DIA	R	SHANK
YTB 133 101	12	6	12
YTB 133 102	15	7.5	12
YTB 133 103	19	9.5	12
YTB 133 104	25	12.5	12
YTB 133 105	28	14	12
YTB 133 106	30	15	12
YTB 133 107	30	17.5	12
YTB 133 108	32	16	12
YTB 133 109	35	17.5	12
YTB 133 110	38	19	12
YTB 133 111	40	20	12
YTB 133 112	50	25	12

Plung Ogee Fillet For Membrane Router Bit - YTB 134



YTB 134				
ORDER CODE	DIA	A (mm)	B (mm)	SHANK
YTB 134 101	25	10	1 / 1.5 / 2 / 2.5	12
YTB 134 102	28	13	1 / 1.5 / 2 / 2.5	12
YTB 134 103	30	14	1 / 1.5 / 2 / 2.5	12
YTB 134 104	32	15	1 / 1.5 / 2 / 2.5	12
YTB 134 105	35	17	1 / 1.5 / 2 / 2.5	12
YTB 134 106	38	18	1 / 1.5 / 2 / 2.5	12
YTB 134 107	40	20	1 / 1.5 / 2 / 2.5	12

Ogee For Membrane Router Bit - YTB 135

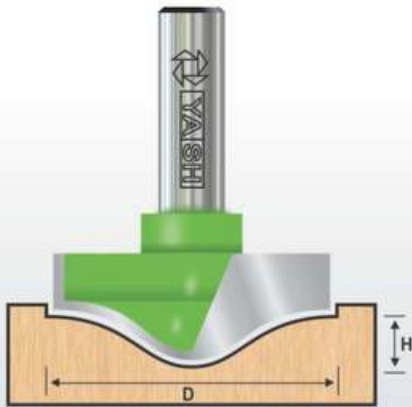

YTB 135

ORDER CODE	DIA	DEPTH (H)	SHANK
YTB 135 101	25	3 / 4 / 5	12
YTB 135 102	28	3 / 4 / 5	12
YTB 135 103	30	3 / 4 / 5	12
YTB 135 104	32	3 / 4 / 5	12
YTB 135 105	35	3 / 4 / 5	12
YTB 135 106	38	3 / 4 / 5	12
YTB 135 107	40	3 / 4 / 5	12

Step Ogee Tool For Membrane Router Bit - YTB 136



YTB 136

ORDER CODE	DIA	A (mm)	DEPTH (H)	SHANK
YTB 136 101	25	10	1 / 1.5 / 2 / 2.5	12
YTB 136 102	28	13	1 / 1.5 / 2 / 2.5	12
YTB 136 103	30	14	1 / 1.5 / 2 / 2.5	12
YTB 136 104	32	15	1 / 1.5 / 2 / 2.5	12
YTB 136 105	35	17	1 / 1.5 / 2 / 2.5	12
YTB 136 106	38	18	1 / 1.5 / 2 / 2.5	12
YTB 136 107	40	20	1 / 1.5 / 2 / 2.5	12

Half Round Wave Board For Membrane Router Bit - YTB 137

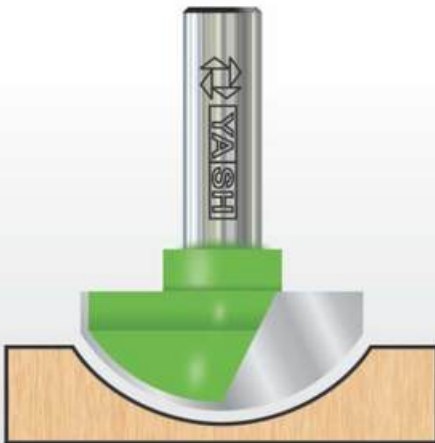

YTB 137

ORDER CODE	DIA	DEPTH (H)	SHANK
YTB 137 101	12	1 / 1.5 / 2 / 2.5	12
YTB 137 102	15	1 / 1.5 / 2 / 2.5	12
YTB 137 103	19	1 / 1.5 / 2 / 2.5	12
YTB 137 104	25	1 / 1.5 / 2 / 2.5	12
YTB 137 105	28	1 / 1.5 / 2 / 2.5	12
YTB 137 106	30	1 / 1.5 / 2 / 2.5	12
YTB 137 107	30	1 / 1.5 / 2 / 2.5	12
YTB 137 108	32	1 / 1.5 / 2 / 2.5	12
YTB 137 109	35	1 / 1.5 / 2 / 2.5	12
YTB 137 110	38	1 / 1.5 / 2 / 2.5	12
YTB 137 111	40	1 / 1.5 / 2 / 2.5	12
YTB 137 112	50	1 / 1.5 / 2 / 2.5	12

Step With Round Tool For Membrane Router Bit - YTB 138

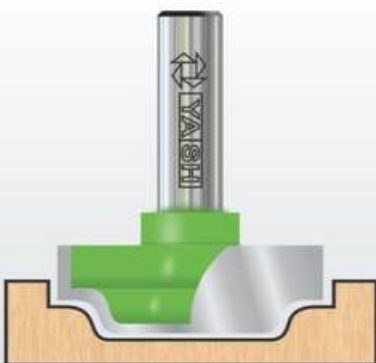

YTB 138

ORDER CODE	DIA	A (mm)	DEPTH (H)	SHANK
YTB 138 101	25	10	1 / 1.5 / 2 / 2.5	12
YTB 138 102	28	13	1 / 1.5 / 2 / 2.5	12
YTB 138 103	30	14	1 / 1.5 / 2 / 2.5	12
YTB 138 104	32	15	1 / 1.5 / 2 / 2.5	12
YTB 138 105	35	17	1 / 1.5 / 2 / 2.5	12
YTB 138 106	38	18	1 / 1.5 / 2 / 2.5	12
YTB 138 107	40	20	1 / 1.5 / 2 / 2.5	12

Step Tool For Membrane Router Bit - YTB 139

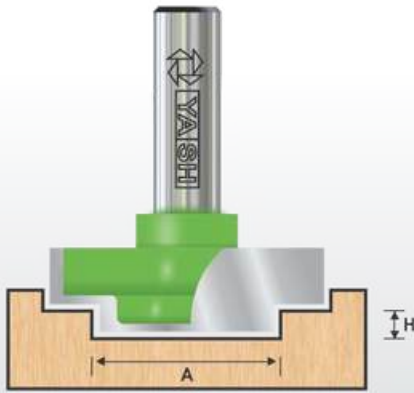

YTB 139				
ORDER CODE	DIA	A (mm)	DEPTH (H)	SHANK
YTB 139 101	25	10	1 / 1.5 / 2 / 2.5	12
YTB 139 102	28	13	1 / 1.5 / 2 / 2.5	12
YTB 139 103	30	14	1 / 1.5 / 2 / 2.5	12
YTB 139 104	32	15	1 / 1.5 / 2 / 2.5	12
YTB 139 105	35	17	1 / 1.5 / 2 / 2.5	12
YTB 139 106	38	18	1 / 1.5 / 2 / 2.5	12
YTB 139 107	40	20	1 / 1.5 / 2 / 2.5	12

Straight Bit Membrane Router Bit - YTB 140



YTB 140			
ORDER CODE	DIA	Cutting Length	SHANK
YTB 140 101	25	12	12
YTB 140 102	28	12	12
YTB 140 103	30	12	12
YTB 140 104	32	12	12
YTB 140 105	35	12	12
YTB 140 106	38	12	12
YTB 140 107	40	12	12
YTB 140 108	45	12	12
YTB 140 109	50	12	12

Round Ogee For Membrane Router Bit - YTB 141

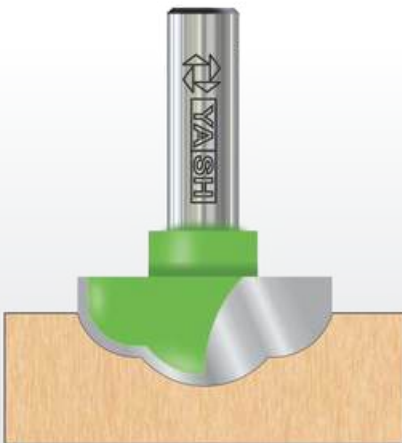

YTB 141			
ORDER CODE	DIA	A (mm)	SHANK
YTB 141 101	25	4 / 6 / 8	12
YTB 141 102	28	4 / 6 / 8	12
YTB 141 103	30	4 / 6 / 8	12
YTB 141 104	32	4 / 6 / 8	12
YTB 141 105	35	4 / 6 / 8	12
YTB 141 106	38	4 / 6 / 8	12
YTB 141 107	40	4 / 6 / 8	12

V Shafe For Membrane Router Bit - YTB 142

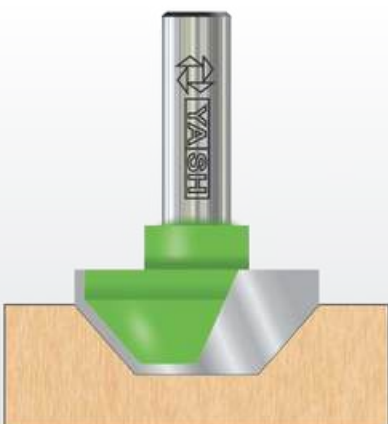

YTB 142				
ORDER CODE	DIA	A (mm)	DEPTH (H)	SHANK
YTB 142 101	25	8	4 / 6 / 8	12
YTB 142 102	28	9	4 / 6 / 8	12
YTB 142 103	30	10	4 / 6 / 8	12
YTB 142 104	32	11	4 / 6 / 8	12
YTB 142 105	35	12	4 / 6 / 8	12
YTB 142 106	38	14	4 / 6 / 8	12
YTB 142 107	40	17	4 / 6 / 8	12

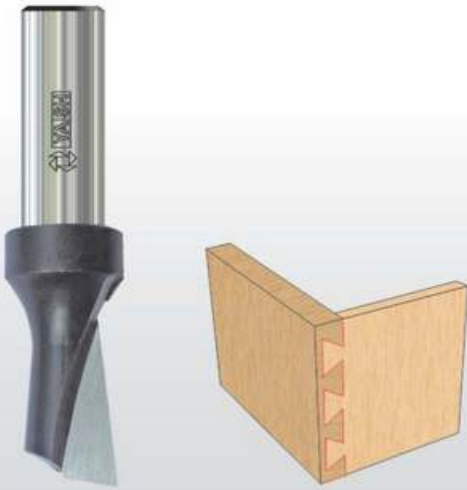

Machines : CNC Router
Material : Solid Wood ,MDF, Particle Board

YTB 143

ORDER CODE	DIA	CL (mm)	SHANK
YTB 143 101	12.7	12.7	12
YTB 143 102	15.8	16	12
YTB 143 103	19.0	20	12
YTB 143 104	25.4	26	12

Dovetail Router Bit - YTB 144



YTB 144

ORDER CODE	DIA	CUTTING LENGTH	SHANK
YTB 144 101	12.7	12.7	12
YTB 144 102	15.8	16	12
YTB 144 103	19	20	12
YTB 144 104	25.4	26	12

Beading Flat Router Bit - YTB 145



YTB 145

ORDER CODE	DIA	MOULDING SIZE	SHANK
YTB 145 101	23	8 x 8	8
YTB 145 102	26	10 x 10	8
YTB 145 103	29	12 x 10	8
YTB 145 104	29	12 x 12	8
YTB 145 105	34	15 x 10	8
YTB 145 106	34	15 x 15	8
YTB 145 107	41	19 x 19	8
YTB 145 108	46	22 x 22	8
YTB 145 109	51	25 x 25	8

Straight Router Bit TCT Brazed - YTB 146

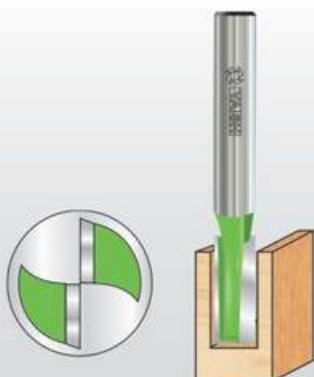

YTB 146

ORDER CODE	DIA	CUTTING LENGTH	SHANK
YTB 146 101	10	50	12
YTB 146 102	12	50	12
YTB 146 103	12	63	12
YTB 146 104	12	75	12
YTB 146 105	19	38	12
YTB 146 106	19	50	12
YTB 146 107	25	25	11
YTB 146 108	25	50	12

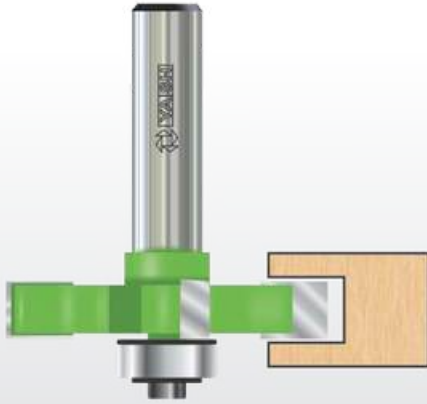

Machines : CNC Router
Material : Solid Wood ,MDF, Particle Board

YTB 147

ORDER CODE	DIA	CUTTING WIDTH	SHANK
YTB 147 101	35	3	8
YTB 147 102	35	4	8
YTB 147 103	35	6	8
YTB 147 104	35	8	8
YTB 147 105	35	10	8
YTB 147 106	35	12	8
YTB 147 107	35	15	8
YTB 147 108	35	19	8

Chamfer Router Bit TCT Brazed - YTB 148

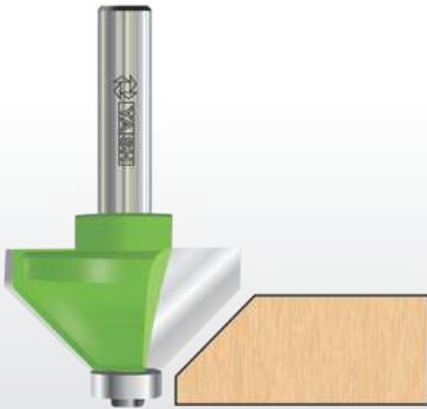

YTB 148

ORDER CODE	DIA	CUTTING WIDTH	SHANK
YTB 148 101	35	15	8
YTB 148 102	35	25	8
YTB 148 103	35	45	8
YTB 148 104	40	45	12
YTB 148 105	45	45	12
YTB 148 106	50	45	12
YTB 148 107	55	45	12

Plung Classical Bit TCT Brazed - YTB 149

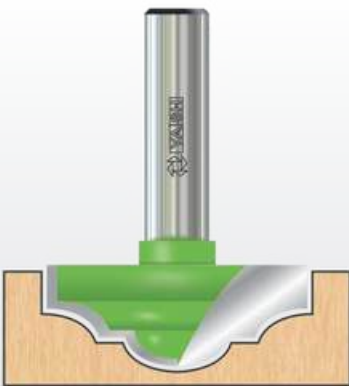

YTB 149

ORDER CODE	DIA	MOULDING SIZE	SHANK
YTB 149 101	15	15 x 10	8
YTB 149 102	19	19 x 10	8
YTB 149 103	22	22 x 10	8
YTB 149 104	25	25 x 10	8
YTB 149 105	25	25 x 12	8
YTB 149 106	32	32 x 12	8

Ovolo Classical Bit TCT Brazed - YTB 150



YTB 150

ORDER CODE	DIA	MOULDING SIZE	SHANK
YTB 150 101	10	10 x 8	8
YTB 150 102	12	12 x 8	8
YTB 150 103	15	15 x 8	8
YTB 150 104	19	19 x 10	8
YTB 150 105	22	22 x 10	8
YTB 150 106	25	25 x 10	8
YTB 150 107	32	32 x 12	8
YTB 150 108	38	38 x 12	8

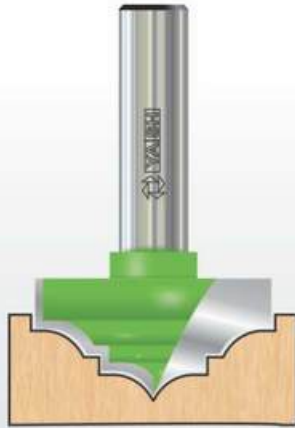

Machines : CNC Router
Material : Solid Wood ,MDF, Particle Board

YTB 151

ORDER CODE	DIA	MOULDING SIZE	SHANK
YTB 151 101	15	15 x 10	8
YTB 151 102	19	19 x 10	8
YTB 151 103	22	22 x 10	8
YTB 151 104	25	25 x 10	8
YTB 151 105	28	28 x 10	8

Spiral Straight Bit TCT Brazed - YTB 152



YTB 152

ORDER CODE	DIA	CUTTING LENGTH	TOTAL LENGTH	SHANK
YTB 152 101	12	35	160	12
YTB 152 102	16	35	160	12
YTB 152 103	18	35	160	12
YTB 152 104	20	35	160	12

Corner Radius Bit TCT Brazed - YTB 153



YTB153

ORDER CODE	DIA	RADIUS	CUTTING LENGTH	SHANK
YTB 153 101	22	4	10	8
YTB 153 102	25	6	11	8
YTB 153 103	30	9	16	8
YTB 153 104	38	12	19	8
YTB 153 105	45	16	22	8
YTB 153 106	51	19	25	12
YTB 153 107	58	22	28	12
YTB 153 108	65	25	32	12

V Groove Bit TCT Brazed - YTB 154



YTB 154

ORDER CODE	DIA	DEGREE	SHANK
YTB 154 101	19	90	12
YTB 154 102	22	90	12
YTB 154 103	25	90	12
YTB 154 104	32	90	12
YTB 154 105	32	120	12
YTB 154 106	32	140	12
YTB 154 107	32	150	12

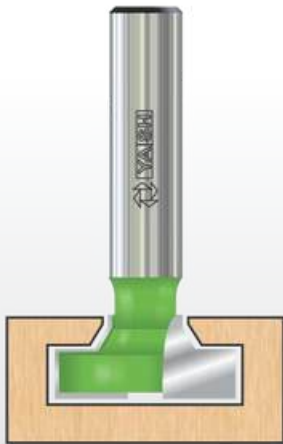

Machines : CNC Router
Material : Solid Wood ,MDF, Particle Board

YTB 155

ORDER CODE	DIA	H1	H1	SHANK
YTB 155 101	29	13.5	8	12

T Slot Bit TCT Brazed - YTB 156



YTB 156

ORDER CODE	DIA	D1	B	H	SHANK
YTB 156 101	9.52	6.35	4.76	9.5	12
YTB 156 102	12.7	6.35	4.76	9.5	12

Door Switch Bit TCT Brazed - YTB 157

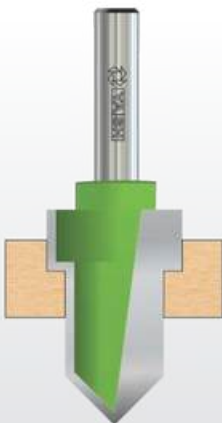

YTB 157

ORDER CODE	DIA	D1	H	SHANK
YTB 157 101	22	18	25	12

Door Router Bit TCT Brazed - YTB 158

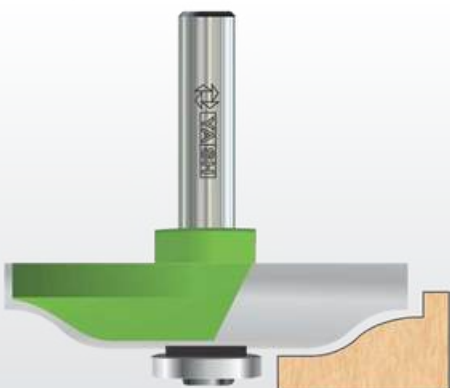

YTB 158

ORDER CODE	DIA	MOULDING SIZE	SHANK
YTB 158 101	43	15 X 5	12

New **Technology**
One **Quality**
One **Name**

Next Generation Tools By



YASH TOOLING SYSTEM

Plot No.: 462, Road No.: 12, Kathwada G. I. D. C., Odhav, Ahmedabad – 382430, Gujarat, INDIA
Phone : +91 9925430880 , 8000630880, 9925412341 **Email** : yashtoolingsystems@gmail.com