

Next Generation Tools By



TCT  
BAND SAW  
BLADE

New Edge of Technology  
DIAMOND  
TECHNOLOGY

Awe-inspiring  
Precision &  
Performance

BRAZE - REPLACEABLE - PCD  
Wood Working Tools

The Sign Of Excellence

Next Generation Tools By



The Company, Yash Tooling System is setting new Benchmarks in tools' designing, manufacturing and overall quality operations. With introduction of these tools with Replaceable Knives, Yash now has the distinction of being the first Indian company to undertake manufacturing of such international quality products. In the late nineties, Brazed tools market was teeming with various manufacturers, yash though being late entrant – acquired a position of premium brand very quickly. Still the quality brazed tools users always prefer Yash over any other product. Yash uses the best European machinery & processes to manufacture its products, with highest quality raw material. In short, Brazed or Replaceable, Yash tools are powered to give unbeatable performance and a long – long working life.

To win the markets, you have to do something extra – ordinary. Yash helps you achieve that. Your wood-work and panel jobs can be crafted so meticulously and consistently qualitatively that your product stand apart from the crowd, making you a winner of the customer choice. Yash Symbolises ultimate quality. Such highly dependable and systematically precision tools, till now were possible with imported brands only. Now you have it here in 'Yash', that too at comparably lower cost and with reliable supply and service support.

# INNOVATIVE TOOLS FOR WOOD WORKING INDUSTRIES

## Our In House Machine Facility

For

ENHANCE QUALITY | BETTER PERFORMANCE | UN BEATABLE PRICE  
FASTEST DELIVERY | AFTER SALES & SERVICE



PCD Grinding



CNC Balancing Machine



Profile Grinding



CNC Profile Grinding



Induction Brazing



CNC Vertical Milling



CNC Turning

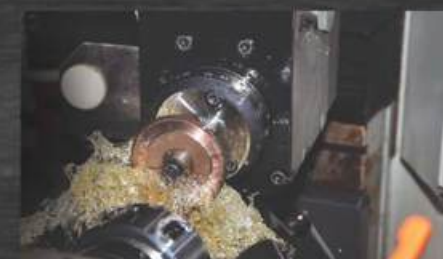



**SMOOTH  
FINISH**

EASY TO CHANGE

**LONG LIFE**

**REPLACEABLE**

Grooving Cutter  
REPLACEABLE

88



Planing Cutter  
REPLACEABLE

90



Counter Profile Counter  
REPLACEABLE

95



Raised Panel Cutter  
REPLACEABLE

97



Cutter Head Set for Door  
REPLACEABLE

99



Glue Joint Cutter  
BRAZE & REPLACEABLE

100



Replaceable Straight Bit

102



Replaceable Facing Tools &  
Replaceable "V" Groove Router

103



Replaceable CNC Router Bit

104



Tct Turnover Knives

113



Trimming Cutter

156



## Adjustable Grooving Cutter ( Replaceable ) - YTR 1 ( 2Pcs Set )



### Technical Details :

Use on Panel Saw & Spindle Moulder

### Application :

With low-alloy steel hardened and tempered body. Suitable for the execution of grooves on toupee machines, double end tenoners, moulding machines, etc.



With Spacer



Without Spacer

### YTR 1

ORDER CODE	DIA	THICKNESS	BORE		TEETH
YTR 1 101	160	4 To 8	30	31.75	8 + 4
YTR 1 102	160	6 To 12	30	31.75	8 + 4
YTR 1 103	160	8 To 15	30	31.75	8 + 4
YTR 1 104	160	15 TO 30	30	31.75	8 + 4
YTR 1 105	160	20 To 40	30	31.75	8 + 4

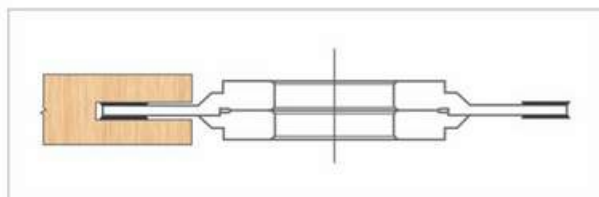

### SPARE

ORDER CODE	KNIVES	SCREW	SPURE	SCREW	RING NUT	WEDGE
YTR 1 101	18X18X1.9	M4 X 3.2C	14x14x2	M5 X 3.2C	11.6 / 1.5	
YTR 1 102	18X18X2.9	M4 X 5C	14x14x2	M5 X 5C	11.6 / 2.5	
YTR 1 103	7.5X12X1.5	M4 X16	14x14x2	M5 X 5C	11.6 / 2.5	7x12x12
YTR 1 104	15X12X1.5	M5X21	14x14x2	M5 X 11	11.6 / 2.5	14x12x12
YTR 1 105	20X12X1.5	M5X21	14x14x2	M5 X 11	11.6 / 2.5	14x12x12

## Adjustable Grooving Cutter ( Replaceable ) - YTR 2 ( 3Pcs Set )



### Technical Details :

Use on Panel Saw & Spindle Moulder

### Application :

With low-alloy steel hardened and tempered body. Suitable for the execution of grooves on toupee machines, double end tenoners, moulding machines, etc.



With Spacer



Without Spacer

### YTR 2

ORDER CODE	DIA	THICKNESS	BORE		TEETH
YTR 2 101	160	4 To 15	30	31.75	12 + 4
YTR 2 102	160	6 To 19	30	31.75	12 + 4

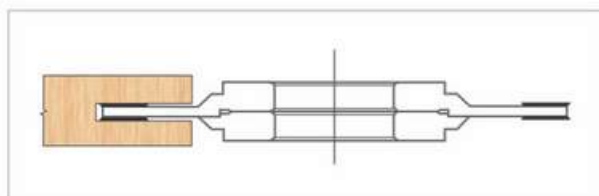

### SPARE

ORDER CODE	KNIVES	SCREW	SPURE	SCREW	RING NUT	WEDGE
YTR 2 101	18X18X1.9	M4 X 3.2C	14X14X2	M5 X 3.2C	11.6 / 1.5	12X12X7
YTR 2 102	18X18X1.9	M4 X 5C	14X14X2	M5 X 5C	11.6 / 2.5	12X12X7





**Technical Details :**

Use on Spindle Moulder , four side Moulder

**Application :**

The plane or groove blade head features 4 resharpenable blazed cutters. These main cutters reduce chipping and lower the kick-back. These cutters are used for planning and rebating in solid wood

**YTR 3**

ORDER CODE	DIA	THICKNESS	BORE		TEETH
YTR 3 101	80	30	30	40	4
YTR 3 102	80	50	30	40	4
YTR 3 103	100	30	30	40	4
YTR 3 104	100	50	30	40	4
YTR 3 105	125	50	30	40	4

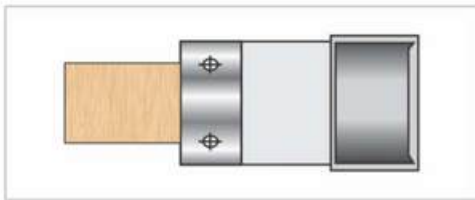

**SPARE**

ORDER CODE	KNIVES	SCREW	WEDGE
YTR 3 101	30X12X1.5	M6X12G	25X12X12
YTR 3 102	50X12X1.5	M6X12G	45X12X12
YTR 3 103	30X12X1.5	M6X12G	25X12X12
YTR 3 104	50X12X1.5	M6X12G	45X12X12
YTR 3 105	30X12X1.5	M6X12G	25X12X12

# Planning Cutter With Helix 2 + 2 Spure ( Replaceable ) - YTR 4



**Technical Details :**

Use on Spindle Moulder , four side Moulder

**Application :**

The plane or groove blade head features 4 resharpenable blazed cutters. These main cutters reduce chipping and lower the kick-back. These cutters are used for planning and rebating in solid wood

**YTR 4**

ORDER CODE	DIA	THICKNESS	BORE		TEETH
YTR 4 101	80	30	30	40	4 + 2
YTR 4 102	80	50	30	40	4 + 2
YTR 4 103	100	30	30	40	4 + 2
YTR 4 104	100	50	30	40	4 + 2
YTR 4 105	125	50	30	40	4 + 2

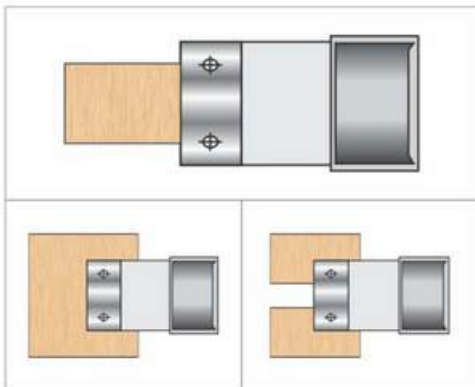

**SPARE**

ORDER CODE	KNIVES	SCREW	SPURE	SCREW	WEDGE
YTR 4 101	30X12X1.5	M6X12G	14X14X2	M5X5C	25X12X12
YTR 4 102	50X12X1.5	M6X12G	14X14X2	M5X5C	45X12X12
YTR 4 103	30X12X1.5	M6X12G	14X14X2	M5X5C	25X12X12
YTR 4 104	50X12X1.5	M6X12G	14X14X2	M5X5C	45X12X12
YTR 4 105	50X12X1.5	M6X12G	14X14X2	M5X5C	45X12X12

Any Customized Specifications Also Can Make As Per Requirements

## Planing Cutter With Helix 3 Spure ( Replaceable ) - YTR 5

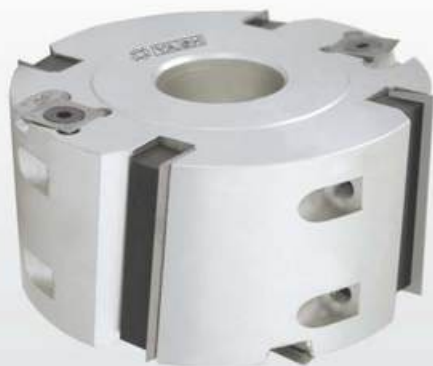

### Technical Details :

Use on Spindle Moulder , four side Moulder

### Application :

The plane or groove blade head features 4 resharpenable blazed cutters. These main cutters reduce chipping and lower the kick-back. These cutters are used for planing and rebating in solid wood

### YTR 5

ORDER CODE	DIA	THICKNESS	BORE		TEETH
YTR 5 101	80	30	30	40	4 + 4
YTR 5 102	80	50	30	40	4 + 4
YTR 5 103	100	30	30	40	4 + 4
YTR 5 104	100	50	30	40	4 + 4
YTR 5 105	125	50	30	40	4 + 4

### SPARE

ORDER CODE	KNIVES	SCREW	SPURE	SCREW	WEDGE
YTR 4 101	30X12X1.5	M6X12G	14X14X2	M5X5C	25X12X12
YTR 4 102	50X12X1.5	M6X12G	14X14X2	M5X5C	45X12X12
YTR 4 103	30X12X1.5	M6X12G	14X14X2	M5X5C	25X12X12
YTR 4 104	50X12X1.5	M6X12G	14X14X2	M5X5C	45X12X12
YTR 4 105	50X12X1.5	M6X12G	14X14X2	M5X5C	45X12X12

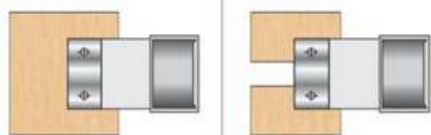
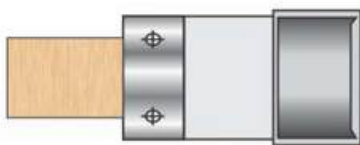

## Spiral Planing Roll For Spindel Moulder ( Replaceable ) - YTR 6

### Technical Details :

Use on Spindle Moulder, four Side Moulder

### Application :

Spiral Aluminum Cutter Head for Planing It's Equipped with 14x14x2mm Knives with 4cutting edges, Particular suitable for excellent finishing. Increased productivity & the tool produces less noise.



Only for planing

### YTR 6

ORDER CODE	DIA	THICKNESS	BORE		SPARE	
					KNIVES	SCREW
YTR 6 101	60	50	30	40	14X14X2	M5X6C
YTR 6 102	60	60	30	40	14X14X2	M5X6C
YTR 6 103	60	80	30	40	14X14X2	M5X6C
YTR 6 104	60	100	30	40	14X14X2	M5X6C
YTR 6 105	80	50	30	40	14X14X2	M5X10C
YTR 6 106	80	60	30	40	14X14X2	M5X10C
YTR 6 107	80	80	30	40	14X14X2	M5X10C
YTR 6 108	80	100	30	40	14X14X2	M5X10C
YTR 6 109	100	50	30	40	14X14X2	M5X10C
YTR 6 110	100	60	30	40	14X14X2	M5X10C
YTR 6 111	100	80	30	40	14X14X2	M5X10C
YTR 6 112	100	100	30	40	14X14X2	M5X10C
YTR 6 113	100	130	30	40	14X14X2	M5X10C



## Spiral Planning Roll For Four Side Planer ( Replaceable ) - YTR 7



### Technical Details :

Use on Spindle Moulder, four Side Moulder

### Application :

Spiral Aluminum Cutter Head for Planing It's Equipped with 14x14x2mm Knives with 4cutting edges, Particular suitable for excellent finishing. Increased productivity & the tool produces less noise.

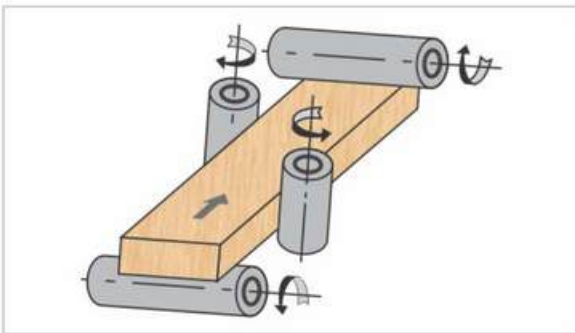

YTR 7				SPARE	
ORDER CODE	DIA	THICKNESS	BORE	KNIVES	SCREW
YTR 7 101	125	30	40	14X14X2	M5X6C
YTR 7 102	125	40	40	14X14X2	M5X6C
YTR 7 103	125	50	40	14X14X2	M5X6C
YTR 7 104	125	60	40	14X14X2	M5X6C
YTR 7 105	125	80	40	14X14X2	M5X10C
YTR 7 106	125	100	40	14X14X2	M5X10C
YTR 7 107	125	130	40	14X14X2	M5X10C
YTR 7 108	125	160	40	14X14X2	M5X10C
YTR 7 109	125	180	40	14X14X2	M5X10C
YTR 7 110	125	200	40	14X14X2	M5X10C
YTR 7 111	125	230	40	14X14X2	M5X10C

## Spiral Planning Roll With Spure For Four Side Planer ( Replaceable ) - YTR 8



### Technical Details :

Use on Spindle Moulder, four Side Moulder

### Application :

Spiral Aluminum Cutter Head for Planing It's Equipped with 14x14x2mm Knives with 4cutting edges, Particular suitable for excellent finishing. Increased productivity & the tool produces less noise.

YTR 8				SPARE		
ORDER CODE	DIA	THICKNESS	BORE	KNIVES	SCREW	SPURE
YTR 8 101	125	30	40	14X14X2	M5X6C	14X14X2
YTR 8 102	125	40	40	14X14X2	M5X6C	14X14X2
YTR 8 103	125	50	40	14X14X2	M5X6C	14X14X2
YTR 8 104	125	60	40	14X14X2	M5X6C	14X14X2
YTR 8 105	125	80	40	14X14X2	M5X10C	14X14X2
YTR 8 106	125	100	40	14X14X2	M5X10C	14X14X2
YTR 8 107	125	130	40	14X14X2	M5X10C	14X14X2
YTR 8 108	125	160	40	14X14X2	M5X10C	14X14X2
YTR 8 109	125	180	40	14X14X2	M5X10C	14X14X2
YTR 8 110	125	200	40	14X14X2	M5X10C	14X14X2
YTR 8 111	125	230	40	14X14X2	M5X10C	14X14X2

## Spiral Planning Roll With Holder ( Replaceable ) - YTR 9



### Technical Details :

Use on Pin Router & CNC Machine

### Application :

Spiral Aluminum Cutter Head for Planing It's Equipped with 14x14x2mm Knives with 4cutting edges, Particular suitable for excellent finishing. Increased productivity & the tool produces less noise.



Only for planing

YTR 9				SPARE	
ORDER CODE	DIA	THICKNESS	SHANK	KNIVES	SCREW
YTR 9 101	60	50	20 / 25	14x14x2	M5X6
YTR 9 102	60	80	20 / 25	14x14x2	M5X6
YTR 9 103	60	100	20 / 25	14x14x2	M5X6
YTR 9 104	80	50	20 / 25	14x14x2	M5X6
YTR 9 105	80	80	20 / 25	14x14x2	M5X6
YTR 9 106	80	100	20 / 25	14x14x2	M5X6

## Spiral Planning Cutter Head For Thickness & Surfacer ( Replaceable ) - YTR 10 (with shaffing)



Up to  
**24"**



### Technical Details :

Use on surface planer machine

### Application :

Smooth Surface Finishing Long Life



YTR 10						SPARE	
ORDER CODE	DIA				THICKNESS	KNIVES	SCREW
YTR 10 101	100	110	120	125	230 ( 9" )	13.8x13.8x2.5	M6X15
YTR 10 102	100	110	120	125	255 ( 10" )	13.8x13.8x2.5	M6X15
YTR 10 103	100	110	120	125	305 ( 12" )	13.8x13.8x2.5	M6X15
YTR 11 104	100	110	120	125	330 ( 13" )	13.8x13.8x2.5	M6X15
YTR 10 105	100	110	120	125	410 ( 16" )	13.8x13.8x2.5	M6X15
YTR 10 106	100	110	120	125	460 ( 18" )	13.8x13.8x2.5	M6X15
YTR 10 107	100	110	120	125	510 ( 20" )	13.8x13.8x2.5	M6X15
YTR 10 108	100	110	120	125	610 ( 24" )	13.8x13.8x2.5	M6X15
YTR 10 109	100	110	120	125	915 ( 36" )	13.8x13.8x2.5	M6X15
YTR 10 110	100	110	120	125	1220 ( 48" )	13.8x13.8x2.5	M6X15



## Spiral Planning Cutter Head For Thickness & Surfacer ( M S Body ) ( Replaceable ) - YTR 11 (with shafting)

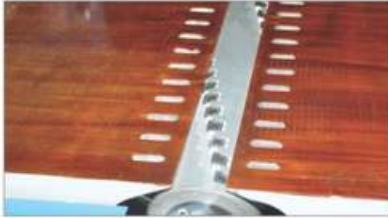

### Technical Details :

Use on surface planer machine

### Application :

Smooth Surface Finishing Long Life

### YTR 11

#### ORDER CODE

#### DIA

#### THICKNESS

### SPARE

#### KNIVES

#### SCREW

YTR 11 101	100	110	120	125	230 ( 9" )	13.8x13.8x2.5	M6X15
YTR 11 102	100	110	120	125	255 ( 10" )	13.8x13.8x2.5	M6X15
YTR 11 103	100	110	120	125	305 ( 12" )	13.8x13.8x2.5	M6X15
YTR 11 104	100	110	120	125	330 ( 13" )	13.8x13.8x2.5	M6X15
YTR 11 105	100	110	120	125	410 ( 16" )	13.8x13.8x2.5	M6X15
YTR 11 106	100	110	120	125	460 ( 18" )	13.8x13.8x2.5	M6X15
YTR 11 107	100	110	120	125	510 ( 20" )	13.8x13.8x2.5	M6X15
YTR 11 108	100	110	120	125	610 ( 24" )	13.8x13.8x2.5	M6X15
YTR 11 109	100	110	120	125	915 ( 36" )	13.8x13.8x2.5	M6X15
YTR 11 110	100	110	120	125	1220 ( 48" )	13.8x13.8x2.5	M6X15

## M S Body Planning Cutter Head( Replaceable ) - YTR 12

HIGHLY RECOMMENDED FOR  
**HARD WOOD**

HIGH PERFORMANCE

**TERSSA Knife**

MADE BY CERATIZIT (GERMANY)



### Technical Details :

Use on surface planer machine

### Application :

Smooth Surface Finishing Long Life

### YTR 12

#### ORDER CODE

#### DIA

#### THICKNESS

#### BORE

#### TEETH

YTR 12 101	125	75	40	4
YTR 12 102	125	80	40	4
YTR 12 103	125	85	40	4
YTR 12 104	125	90	40	4
YTR 12 105	125	100	40	4
YTR 12 106	125	125	40	4
YTR 12 107	125	150	40	4
YTR 12 108	125	170	40	4
YTR 12 109	125	200	40	4
YTR 12 110	125	230	40	4



**Technical Details :**

Use on Spindle Moulder

**Application :**

These very popular design cutters are useful in kitchen shutters. Yash cutters spell a different class in itself. The finish of the wood and cutter life works in your advantage. The cutters can achieve simple or complex profiling.

YTR 13						
ORDER CODE	DIA	WOOD THICKNESS	BORE			TEETH
YTR 13 101	125	18 To 20	30	31.75	35	3
YTR 13 102	125	18 To 20	30	31.75	35	3
YTR 13 103	125	18 To 20	30	31.75	35	3
YTR 13 104	125	18 To 20	30	31.75	35	3
YTR 13 105	125	18 To 20	30	31.75	35	3
YTR 13 106	125	18 To 20	30	31.75	35	3

SPARE			
ORDER CODE	KNIVES	WEDGE	SCREW
YTR 13 101	30x30x2	29x17x10	M6X20G
YTR 13 102	30x30x2	29x17x10	M6X20G
YTR 13 103	30x30x2	29x17x10	M6X20G
YTR 13 104	30x30x2	29x17x10	M6X20G
YTR 13 105	30x30x2	29x17x10	M6X20G
YTR 13 106	30x30x2	29x17x10	M6X20G

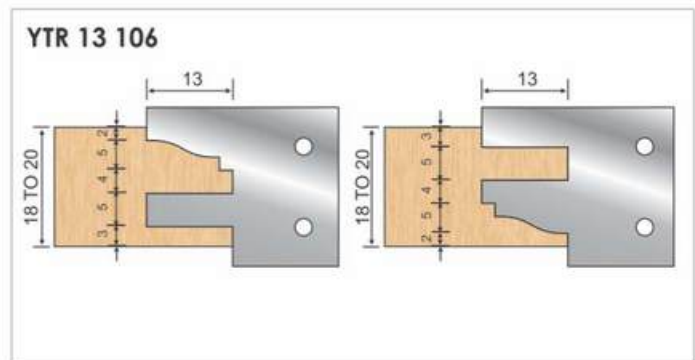
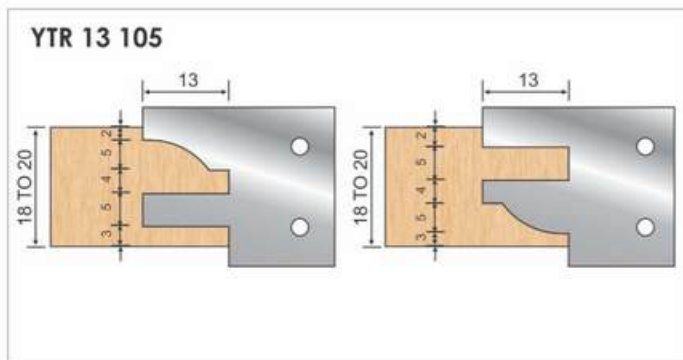
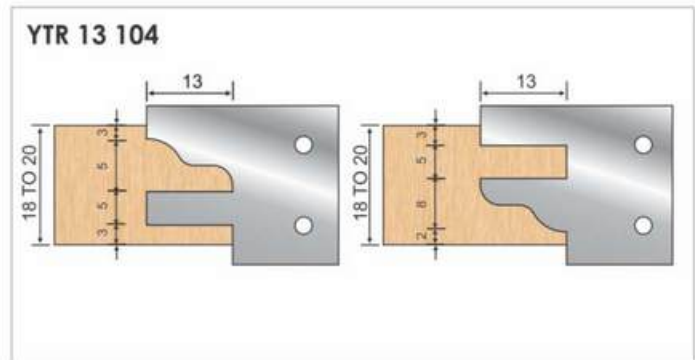
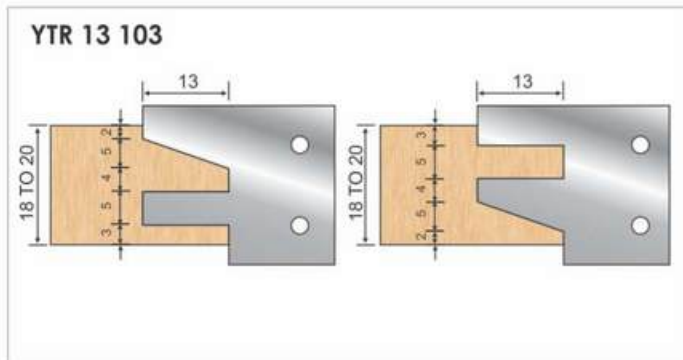
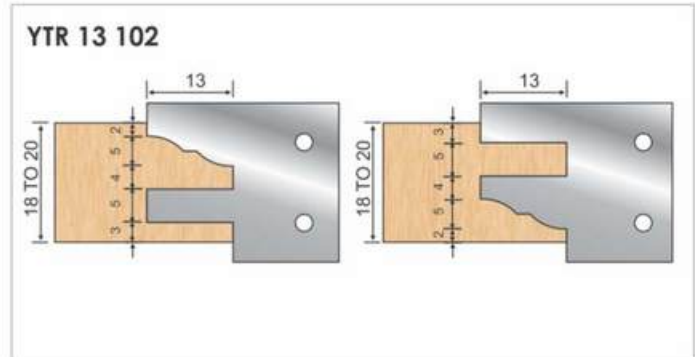
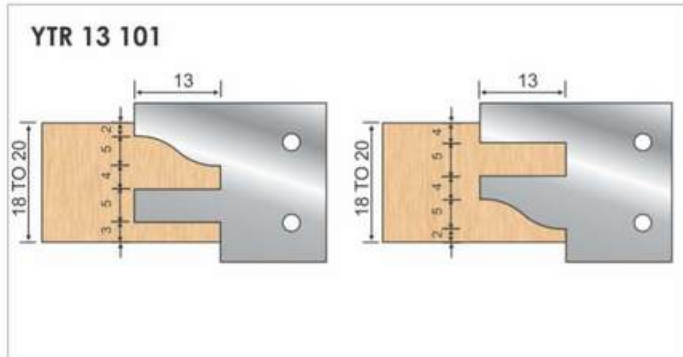





**Technical Details :**

Use on Spindle Moulder

**Application :**

These very popular design cutters are useful in kitchen shutters. Yash cutters spell a different class in itself. The finish of the wood and cutter life works in your advantage. The cutters can achieve simple or complex profiling.

YTR 14						
ORDER CODE	DIA	WOOD THICKNESS	BORE			TEETH
YTR 14 101	125	22 To 24	30	31.75	35	3
YTR 14 102	125	22 To 24	30	31.75	35	3
YTR 14 103	125	22 To 24	30	31.75	35	3
YTR 14 104	125	22 To 24	30	31.75	35	3
YTR 14 105	125	22 To 24	30	31.75	35	3
YTR 14 106	125	22 To 24	30	31.75	35	3

SPARE			
ORDER CODE	KNIVES	WEDGE	SCREW
YTR 14 101	30x30x2	29x17x10	M6X20G
YTR 14 102	30x30x2	29x17x10	M6X20G
YTR 14 103	30x30x2	29x17x10	M6X20G
YTR 14 104	30x30x2	29x17x10	M6X20G
YTR 14 105	30x30x2	29x17x10	M6X20G
YTR 14 106	30x30x2	29x17x10	M6X20G

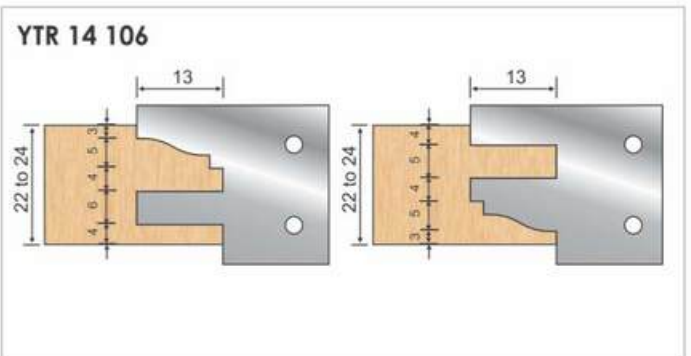
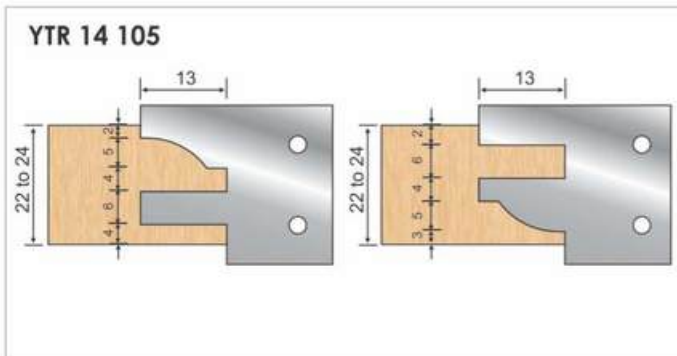
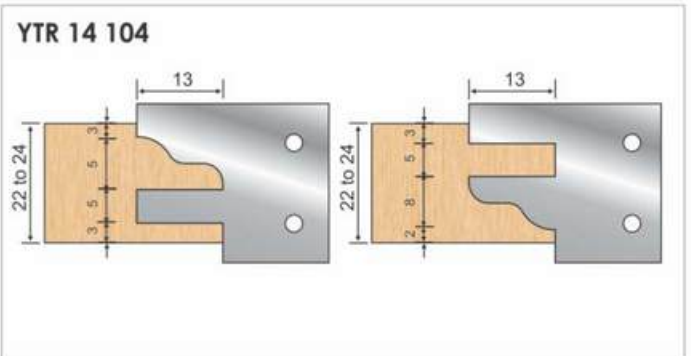
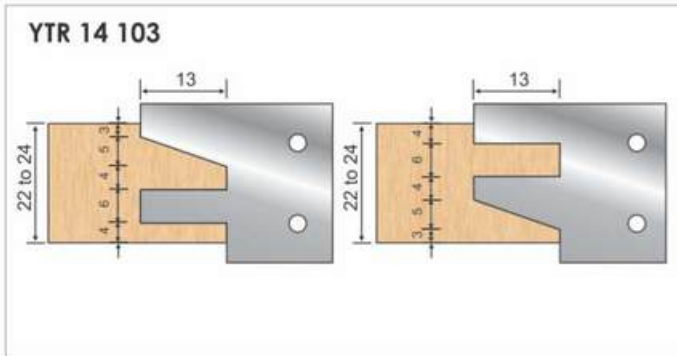
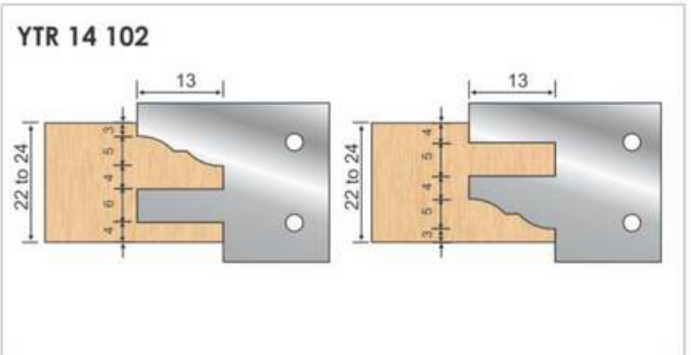
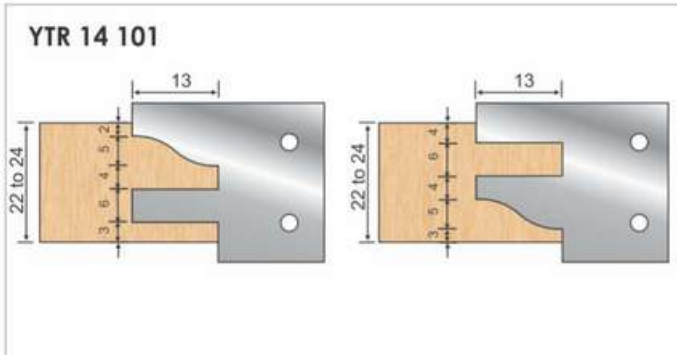



### Technical Details :

Use on Spindle Moulder

### Application :

Make your classic raised panels on furniture, interior and cabinet doors in solid wood and wooden boards, obtaining two or three different roles. To be used in your spindle moulders. Perfect in all materials, but ideal on solid woods and panel materials.

### SPARE

ORDER CODE	KNIVES	WEDGE	SCREW	STOPER
YTR 15	50x25x2	45x12x9	M8X12	M5X8
YTR 15	40x25x2	40x12x9	M8X12	M5X8

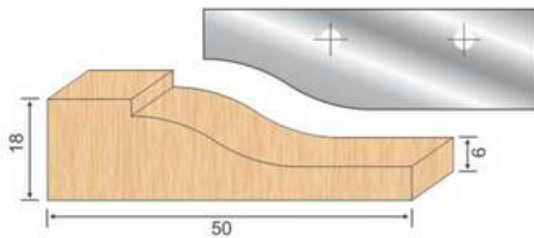

YTR 15							
ORDER CODE	DIA	WOOD THICKNESS	BORE		TEETH		
YTR 15 101	175	40 x 18	30	31.75	35	3	RH
YTR 15 102	175	40 x 18	30	31.75	35	3	LH
YTR 15 103	175	50 x 18	30	31.75	35	3	RH
YTR 15 104	175	50 x 18	30	31.75	35	3	LH

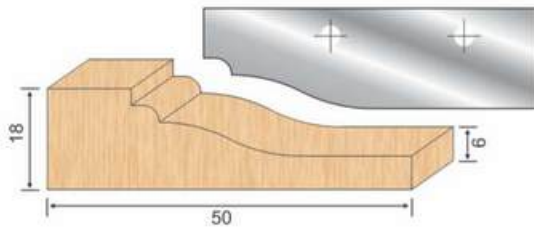

YTR 15							
ORDER CODE	DIA	WOOD THICKNESS	BORE		TEETH		
YTR 15 105	175	40 x 18	30	31.75	35	3	RH
YTR 15 106	175	40 x 18	30	31.75	35	3	LH
YTR 15 107	175	50 x 18	30	31.75	35	3	RH
YTR 15 108	175	50 x 18	30	31.75	35	3	LH

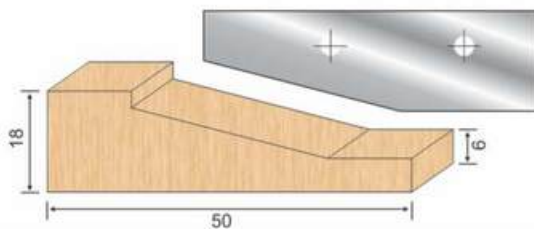

YTR 15							
ORDER CODE	DIA	WOOD THICKNESS	BORE		TEETH		
YTR 15 109	175	40 x 18	30	31.75	35	3	RH
YTR 15 110	175	40 x 18	30	31.75	35	3	LH
YTR 15 111	175	50 x 18	30	31.75	35	3	RH
YTR 15 112	175	50 x 18	30	31.75	35	3	LH

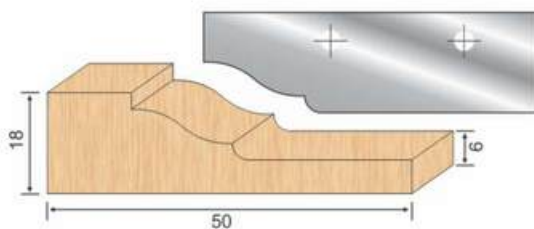

YTR 15							
ORDER CODE	DIA	WOOD THICKNESS	BORE		TEETH		
YTR 15 113	175	40 x 18	30	31.75	35	3	RH
YTR 15 114	175	40 x 18	30	31.75	35	3	LH
YTR 15 115	175	50 x 18	30	31.75	35	3	RH
YTR 15 116	175	50 x 18	30	31.75	35	3	LH

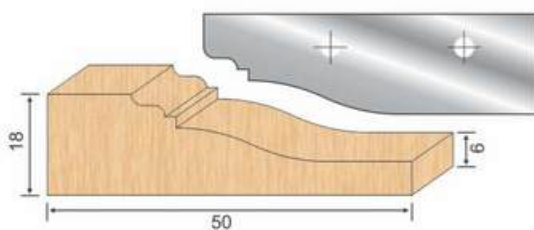

YTR 15							
ORDER CODE	DIA	WOOD THICKNESS	BORE		TEETH		
YTR 15 117	175	40 x 18	30	31.75	35	3	RH
YTR 15 118	175	40 x 18	30	31.75	35	3	LH
YTR 15 119	175	50 x 18	30	31.75	35	3	RH
YTR 15 120	175	50 x 18	30	31.75	35	3	LH





**Technical Details :**

Use on Spindle Moulder

**Application :**

Make your classic raised panels on furniture, interior and cabinet doors in solid wood and wooden boards, obtaining two or three different roles. To be used in your spindle moulders. Perfect in all materials, but ideal on solid woods and panel materials.

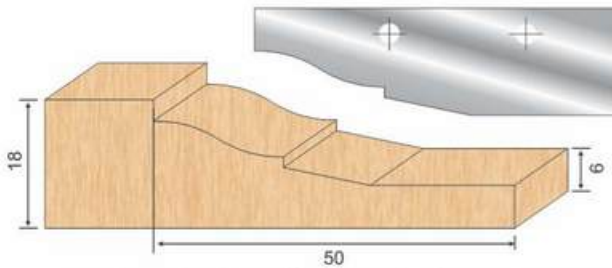
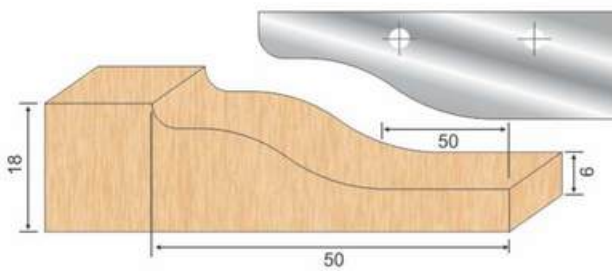
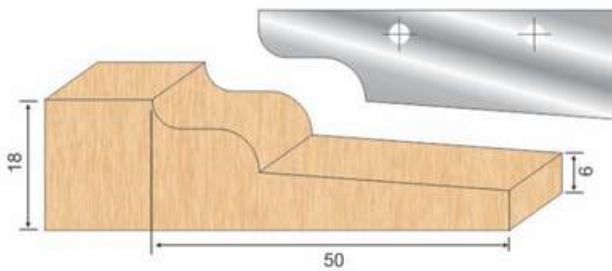
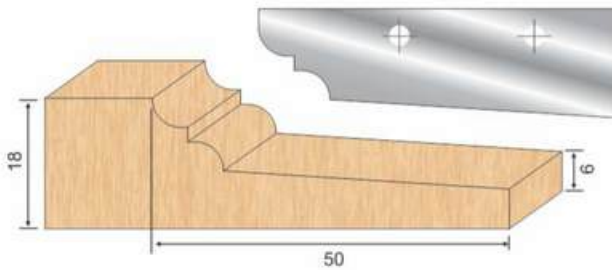
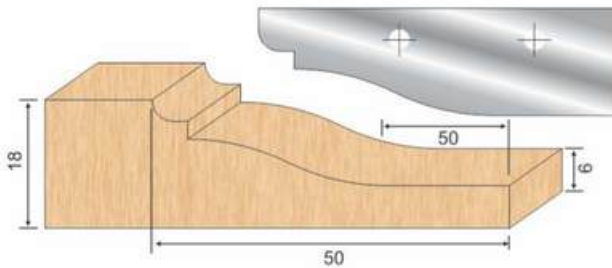
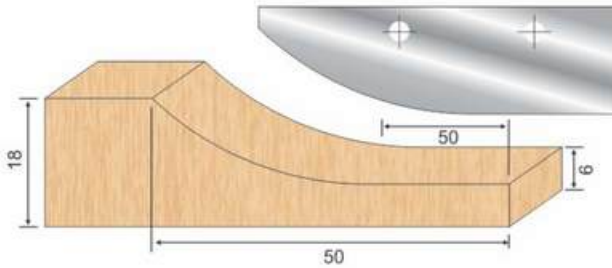

YTR 15							
ORDER CODE	DIA	WOOD THICKNESS	BORE			TEETH	
YTR 15 121	175	40 x 18	30	31.75	35	3	RH
YTR 15 122	175	40 x 18	30	31.75	35	3	LH
YTR 15 123	175	50 x 18	30	31.75	35	3	RH
YTR 15 124	175	50 x 18	30	31.75	35	3	LH

YTR 15							
ORDER CODE	DIA	WOOD THICKNESS	BORE			TEETH	
YTR 15 125	175	40 x 18	30	31.75	35	3	RH
YTR 15 126	175	40 x 18	30	31.75	35	3	LH
YTR 15 127	175	50 x 18	30	31.75	35	3	RH
YTR 15 128	175	50 x 18	30	31.75	35	3	LH

YTR 15							
ORDER CODE	DIA	WOOD THICKNESS	BORE			TEETH	
YTR 15 129	175	40 x 18	30	31.75	35	3	RH
YTR 15 130	175	40 x 18	30	31.75	35	3	LH
YTR 15 131	175	50 x 18	30	31.75	35	3	RH
YTR 15 132	175	50 x 18	30	31.75	35	3	LH

YTR 15							
ORDER CODE	DIA	WOOD THICKNESS	BORE			TEETH	
YTR 15 133	175	40 x 18	30	31.75	35	3	RH
YTR 15 134	175	40 x 18	30	31.75	35	3	LH
YTR 15 135	175	50 x 18	30	31.75	35	3	RH
YTR 15 136	175	50 x 18	30	31.75	35	3	LH

YTR 15							
ORDER CODE	DIA	WOOD THICKNESS	BORE			TEETH	
YTR 15 137	175	40 x 18	30	31.75	35	3	RH
YTR 15 138	175	40 x 18	30	31.75	35	3	LH
YTR 15 139	175	50 x 18	30	31.75	35	3	RH
YTR 15 140	175	50 x 18	30	31.75	35	3	LH

YTR 15							
ORDER CODE	DIA	WOOD THICKNESS	BORE			TEETH	
YTR 15 141	175	40 x 18	30	31.75	35	3	RH
YTR 15 142	175	40 x 18	30	31.75	35	3	LH
YTR 15 143	175	50 x 18	30	31.75	35	3	RH
YTR 15 144	175	50 x 18	30	31.75	35	3	LH

Any Customized Specifications Also Can Make As Per Requirements

# Cutter Head Set For Door Extra Long Tenon ( Replaceable ) - YTR 16

### Technical Details :

Use on Spindle Moulder

### Application :

The heads for making profiles & counterprofiles are fitted with profiled knives 1 & 2 which are then interchangeable. Extra long tenons gives good quality of door-working while making doors very sturdy.

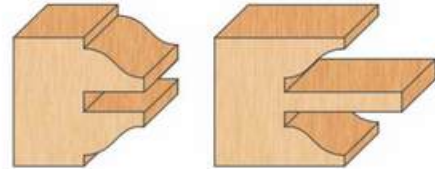

YTR 16								
ORDER CODE	DIA	WOOD THICKNESS	BORE		TEETH	SPARE		
YTR 16 101	125 / 200	32 To 40	30	31.75	35	3 + 2	Knives	20 x 30 x 2
YTR 16 102	125 / 200	32 To 40	30	31.75	35	3 + 2	Screw	M8 x12
YTR 16 103	125 / 200	32 To 40	30	31.75	35	3 + 2	Spure	14 x14 x 2
YTR 16 104	125 / 200	32 To 40	30	31.75	35	3 + 2	Screw	M5 x 2 C
YTR 16 105	125 / 200	32 To 40	30	31.75	35	3 + 2	Knives	7.5 x 12 x 1.5
YTR 16 106	125 / 200	32 To 40	30	31.75	35	3 + 2	Wedge	12 x 12 x 7
							Stopper	M5 x 8B
							Torx Key	3mm / 8mm

### PAIR KNIVES

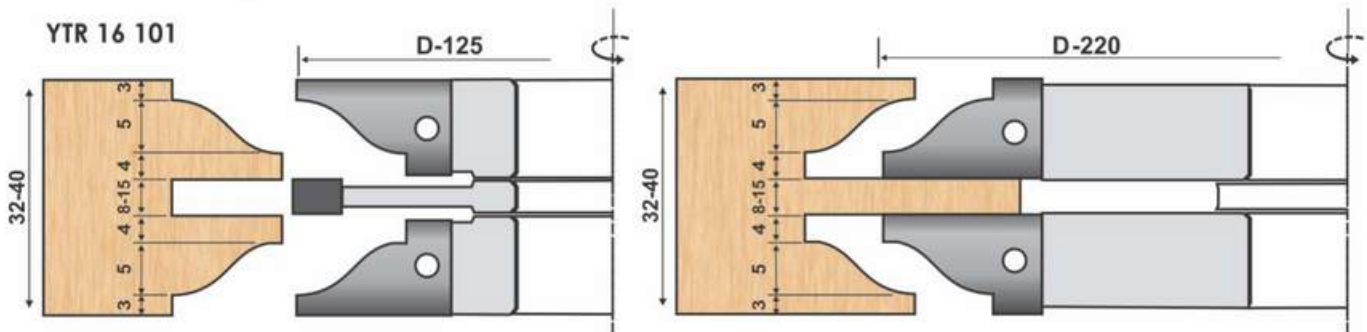

### OPTIONAL KNIVES

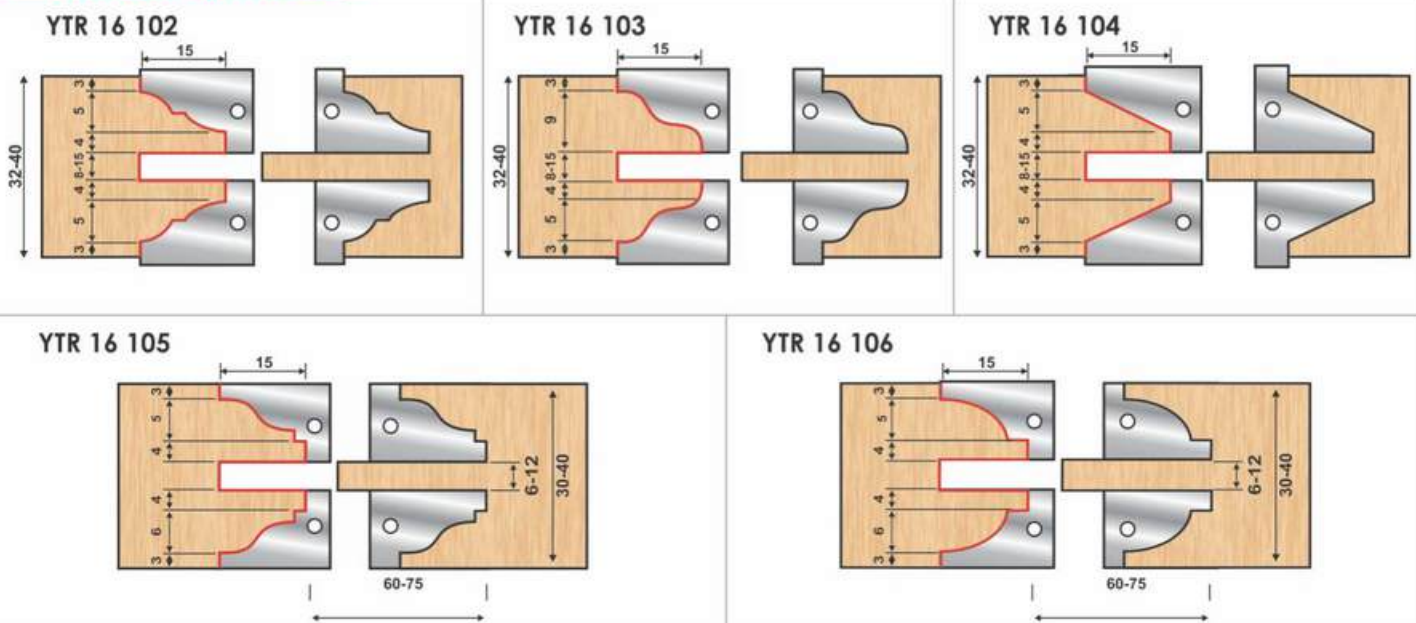

**Note :** You need a separate tool body for these 2 designs.

Any Customized Specifications Also Can Make As Per Requirements





**Technical Details :**

Use on Spindle Molder Machines, Double-end Tenoners and Shapers Machines

**Application :**

Use for wood jointing on edges.



**YTR 17**

ORDER CODE	DIA	WOOD THICKNESS	BORE			TEETH
YTR 17 101	125	14 To 20	30	31.75	35	3
YTR 17 102	125	20 To 30	30	31.75	35	3
YTR 17 103	125	30 TO 40	30	31.75	35	3
YTR 17 104	125	40 To 50	30	31.75	35	3
YTR 17 105	125	40 To 50	30	31.75	35	3

**SPARE**

ORDER CODE	KNIVES	WEDGE	SCREW	STOPER
YTR 17	50x25x2	50x25x10.5	M8X12	M5X8B

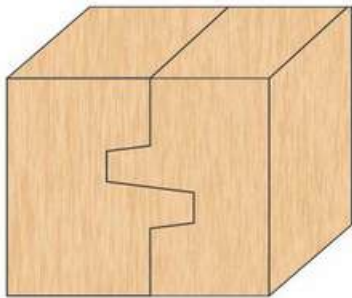

**YTR 17 101**

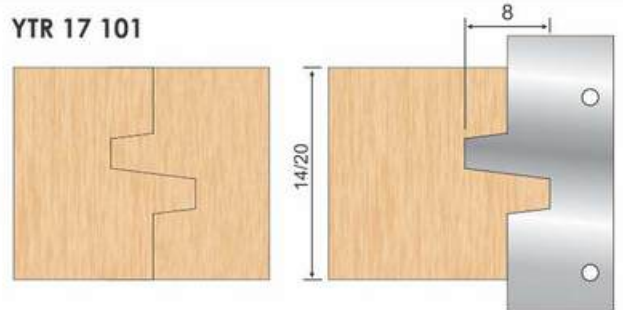

**YTR 17 102**

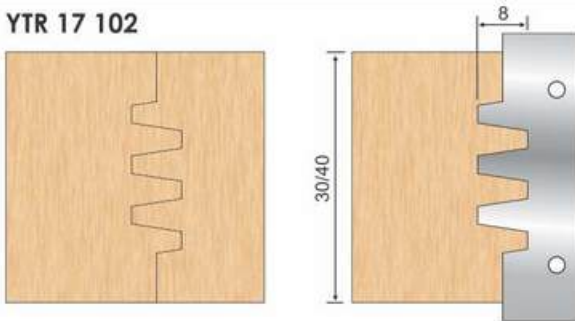

**YTR 17 103**

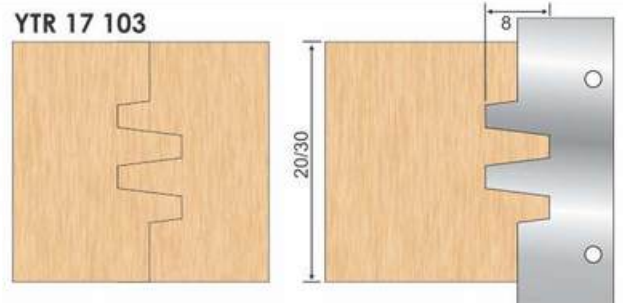

**YTR 17 104**

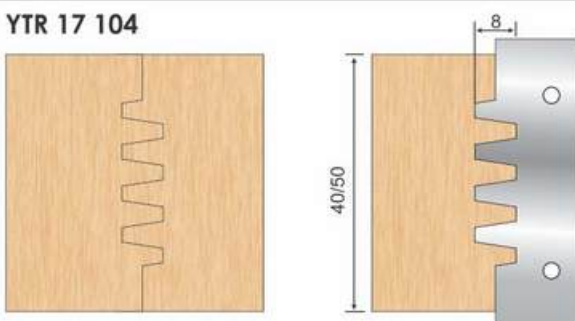

**YTR 17 105**

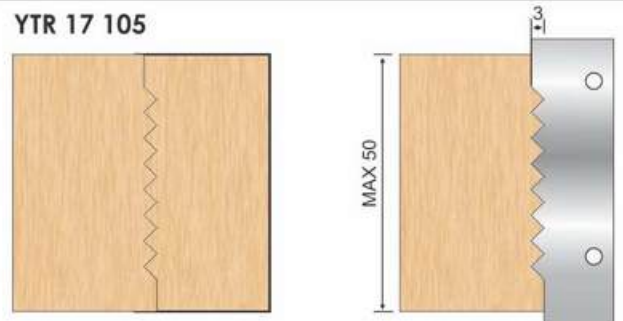

# Chamfer Cutter ( Replaceable ) - YTR 18



### Technical Details :

Use on Spindle Moulder

### Application :

Bevel and chamfer trim bits with two replaceable knives fixed by special torx screws. The knife are 4 sided sharpened and gives three extra new edges. For precision work on laminates, MDF or quick rounded edges in hard wood. for use on portable routers or CNC machining centers.

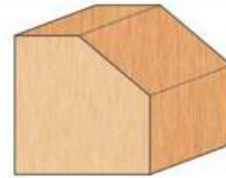

YTR 18								SPARE				
ORDER CODE	DIA	THICKNESS	DEGREE	BORE			TEETH	ORDER CODE	KNIVES	WEDGE	SCREW	STOPER
YTR 18 101	125	30mm	45°	30	31.75	35	4	YTR 18 101	30x12x1.5	25X44X10	M6X12	M5X8B
YTR 18 102	150	40mm	45°	30	31.75	35	4	YTR 18 102	40x12x1.5	35X44X10	M6X12	M5X8B
YTR 18 103	175	50mm	45°	30	31.75	35	4	YTR 18 103	50x12x1.5	45X44X10	M6X12	M5X8B

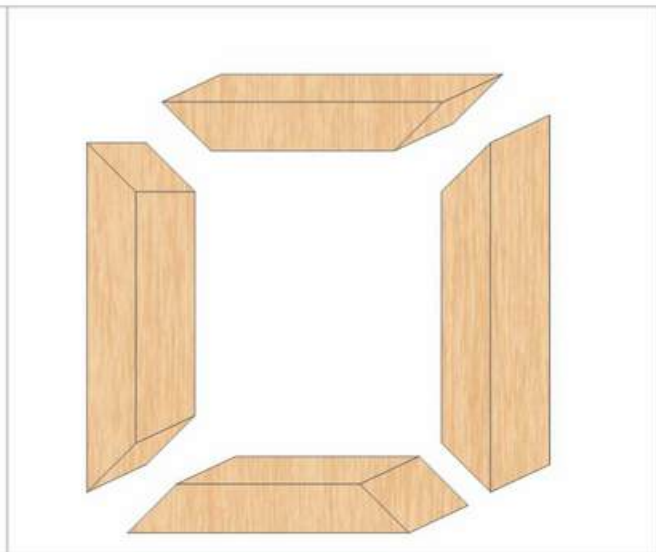
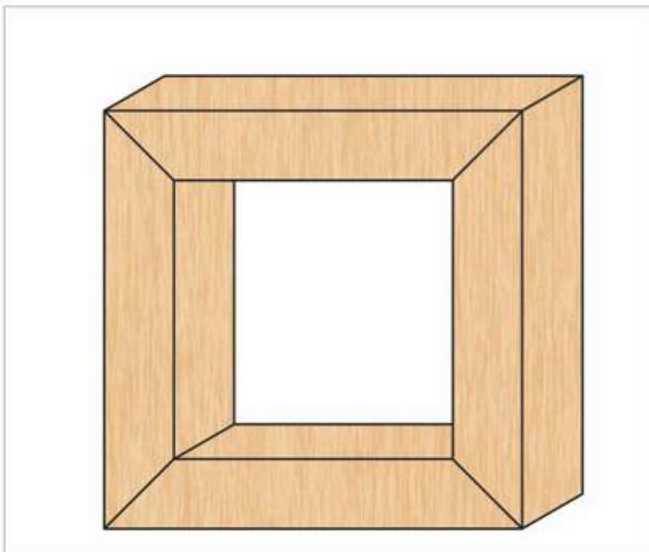
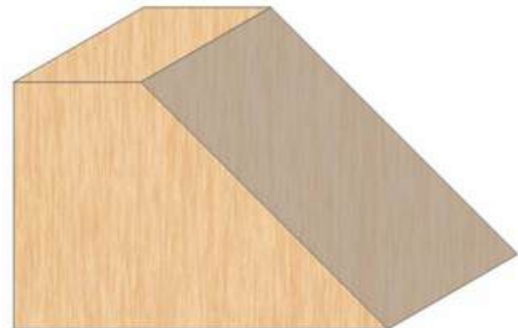
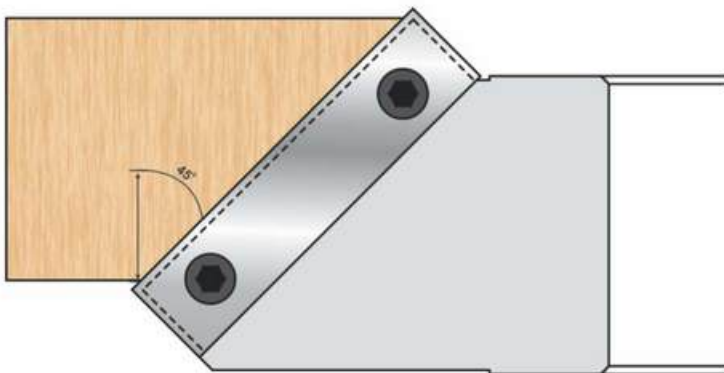



## Straight Router Bit For Laminated ( Replaceable ) - YTR 19

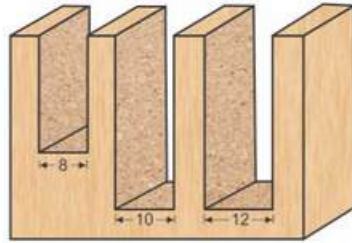

### Technical Details :

Use on CNC Machine & Highspeed Router Machine

### Application :

Straight router bit with replaceable mini knife and fixing wedge. Radial and axial groove for better and safe knife insertion. For finishing, routing and grooving in board materials (DTD laminated, MDF and hardwood). For use on portable routers or CNC machining centres.

YTR 19					SPARE		
ORDER CODE	DIA	CUTTING LENGTH	SHANK	TEETH	KNIFE	SCREW	WEDGES
YTR 19 101	8	20	12	1	20 x 4.1 x 1.1	M2.5X5	18X4X4
YTR 19 102	9	30	12	1	30 x 5.5 x 1.1	M2.5X5	28X5X5
YTR 19 103	10	20	12	1	20 x 5.5 x 1.1	M2.5X5	18X4X4
YTR 19 104	10	30	12	1	30 x 5.5 x 1.1	M2.5X5	28X5X5
YTR 19 105	11	30	12	1	30 x 5.5 x 1.1	M2.5X5	28X5X5
YTR 19 106	12	20	12	1	20 x 5.5 x 1.1	M2.5X5	18X4X4
YTR 19 107	12	30	12	1	30 x 5.5 x 1.1	M2.5X5	28X5X5
YTR 19 108	12	50	12	1	50 x 5.5 x 1.1	M2.5X5	49X5X4

## Straight Router Bit With Extra Plugging Knife ( Replaceable ) - YTR 20

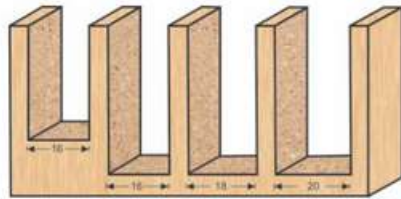

### Technical Details :

Use on CNC Machine & Highspeed Router Machine

### Application :

Straight router bit with replaceable mini knife and fixing wedge. Radial and axial groove for better and safe knife insertion. For finishing, routing and grooving in board materials (DTD laminated, MDF and hardwood). For use on portable routers or CNC machining centres.

YTR 20					SPARE			
ORDER CODE	DIA	CUTTING LENGTH	SHANK	TEETH	KNIFE	KNIFE	SCREW	SCREW
YTR 20 101	16	30	12 / 16	2	30 x 12 x 1.5	7.5 x 12 x 1.5	M 4 x 5 B	M3.5X3
YTR 20 102	16	50	12 / 16	2	50 x 12 x 1.5	7.5 x 12 x 1.5	M 4 x 5 B	M3.5X3
YTR 20 103	18	50	12 / 16	2	50 x 12 x 1.5	7.5 x 12 x 1.5	M 4 x 5 B	M3.5X3
YTR 20 104	20	50	16 / 20	2	50 x 12 x 1.5	7.5 x 12 x 1.5	M 4 x 5 B	M3.5X3

## Straight Router Bit For Laminated ( Replaceable ) - YTR 21



### Technical Details :

Use on CNC Machine & Highspeed Router Machine

### Application :

Straight router bit with replaceable mini knife and fixing wedge. Radial and axial groove for better and safe knife insertion. For finishing, routing and grooving in board materials (DTD laminated, MDF and hardwood). For use on portable routers or CNC machining centres.

YTR 21				
ORDER CODE	DIA	CUTTING LENGTH	SHANK	TEETH
YTR 21 101	16	30	12 / 16	1
YTR 21 102	16	50	12 / 16	1
YTR 21 103	18	30	12 / 16	1
YTR 21 104	18	50	16 / 20	1
YTR 21 105	20	30	12 / 16	1
YTR 21 106	20	50	16 / 20	1

SPARE		
ORDER CODE	KNIFE	SCREW
YTR 21 101, 103, 105	30 x 12 x 1.5	M4X5B
YTR 21 102, 104, 106	50 x 12 x 1.5	M4X5B

# Facing Tool ( Replaceable ) - YTR 22



### Technical Details :

Use on CNC Router Machine

### Application :

The new router bit for CNC routers is ideal for fast removal of material over a large surface area leaving an improved finish at the bottom of the cut. Used on soft and hardwood, particle board and MDF.

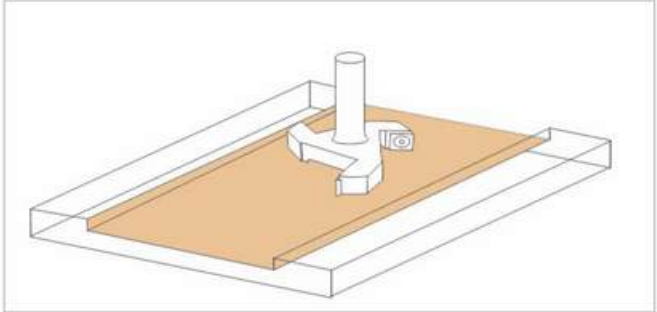

YTR 22				
ORDER CODE	DIA	CUTTING LENGTH	SHANK	TEETH
YTR 22 101	60	14	12 / 16 / 20	3
YTR 22 102	80	14	12 / 16 / 20	3

SPARE		
ORDER CODE	KNIFE	SCREW
YTR 22	14 X 14X 2	M 5 x 5 C

# 90° V Groove Bit ( Replaceable ) - YTR 23



### Technical Details :

Use on CNC Router Machine

### Application :

This great degree router works for V - groove , miter folds , sign making , lettering & chamfer edges . Tool has a high grade reversible knife , ideal for general purpose , chip board , plywood . Even higher grade knife is available for laminated and MDF .

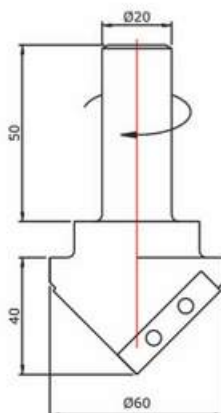
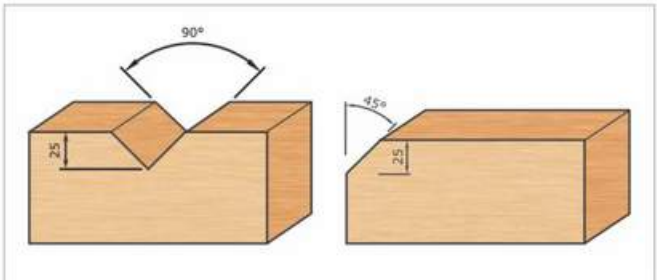

YTR 23				
ORDER CODE	DIA	DEGREE	SHANK	TEETH
YTR 23 101	60	90°	12	2

SPARE		
KNIFE	KNIFE	SCREW
30 X 12 X 1.5	20 X 12 X 1.5	M 4 x 5 B





**Technical Details :**

Use on CNC Router Machine

**Application :**

Specially designed to perform difficult trimming operations, these bits are both indispensable and economical. Flush trim bits with two replaceable knives fixed by special TORX® screws. The 2-sided blades can create extra new edges.

YTR 24					SPARE	
ORDER CODE	DIA	DEPTH	SHANK	TEETH	KNIFE	SCREW
YTR 24 101	35	4mm / 6mm / 8mm	12	1	35 X 25 X 2	M4 X 8B
YTR 24 102	35	4mm / 6mm / 8mm	12	1	35 X 25 X 2	M4 X 8B
YTR 24 103	35	4mm / 6mm / 8mm	12	1	35 X 25 X 2	M4 X 8B
YTR 24 104	35	4mm / 6mm / 8mm	12	1	35 X 25 X 2	M4 X 8B
YTR 24 105	35	4mm / 6mm / 8mm	12	1	35 X 25 X 2	M4 X 8B

YTR 24 101

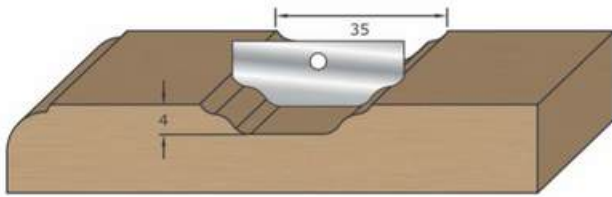

YTR 24 102

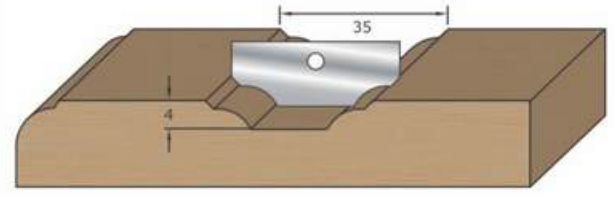

YTR 24 103

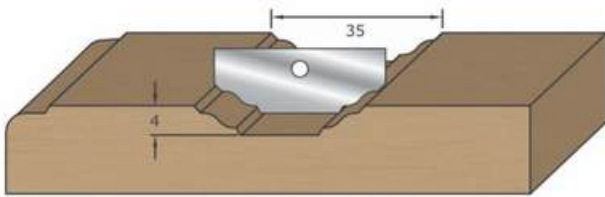

YTR 24 104

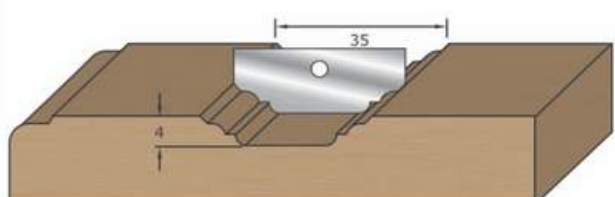

YTR 24 105

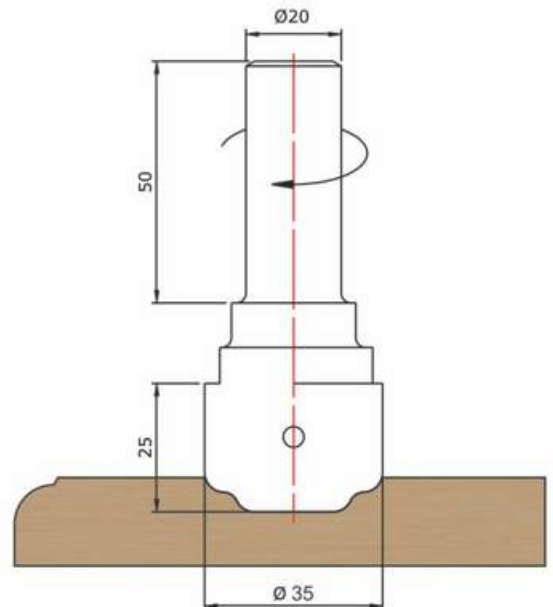
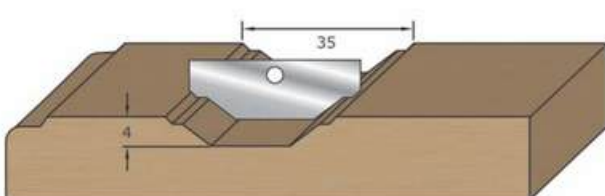



**Technical Details :**

Use on CNC Router Machine

**Application :**

Specially designed to perform difficult trimming operations, these bits are both indispensable and economical. Flush trim bits with two replaceable knives fixed by special TORX® screws. The 2-sided blades can create extra new edges.

YTR 24					SPARE	
ORDER CODE	DIA	DEPTH (H)	SHANK	TEETH	KNIFE	SCREW
YTR 24 106	35	4mm / 6mm / 8mm	12	1	35 X 25 X 2	M4 X 8B
YTR 24 107	35	4mm / 6mm / 8mm	12	1	35 X 25 X 2	M4 X 8B
YTR 24 108	35	4mm / 6mm / 8mm	12	1	35 X 25 X 2	M4 X 8B
YTR 24 109	35	4mm / 6mm / 8mm	12	1	35 X 25 X 2	M4 X 8B
YTR 24 110	35	4mm / 6mm / 8mm	12	1	35 X 25 X 2	M4 X 8B
YTR 24 111	35	4mm / 6mm / 8mm	12	1	35 X 25 X 2	M4 X 8B
YTR 24 112	35	4mm / 6mm / 8mm	12	1	35 X 25 X 2	M4 X 8B
YTR 24 113	35	4mm / 6mm / 8mm	12	1	35 X 25 X 2	M4 X 8B

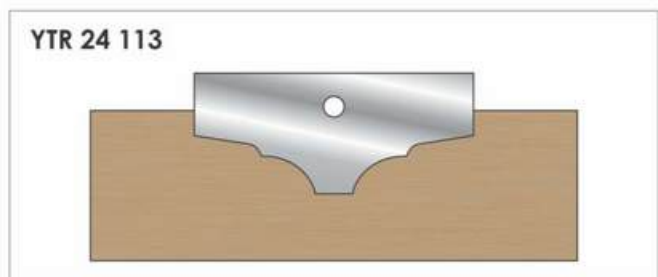
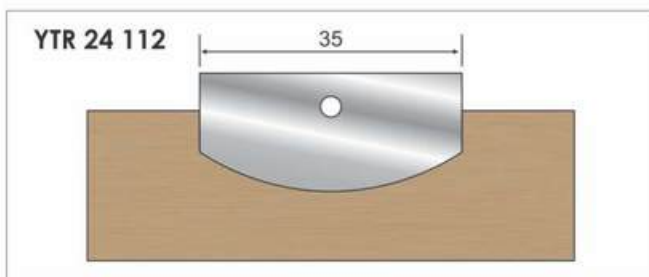
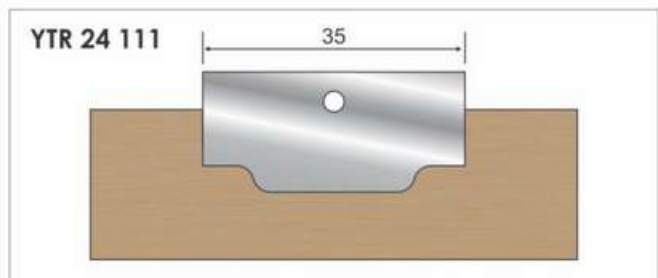
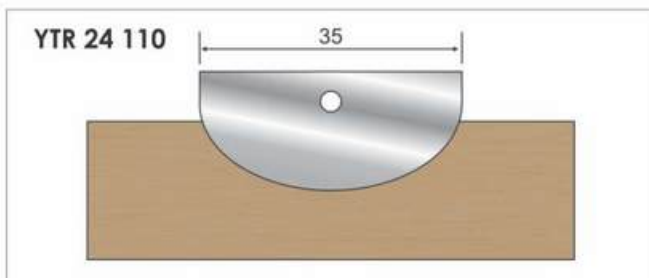
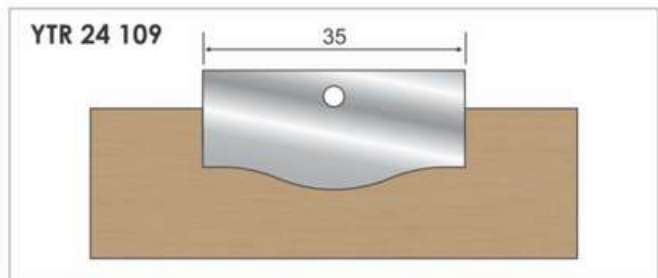
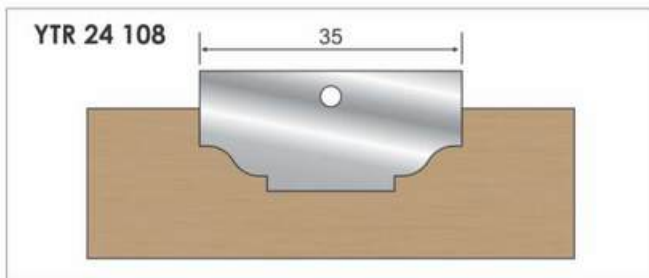
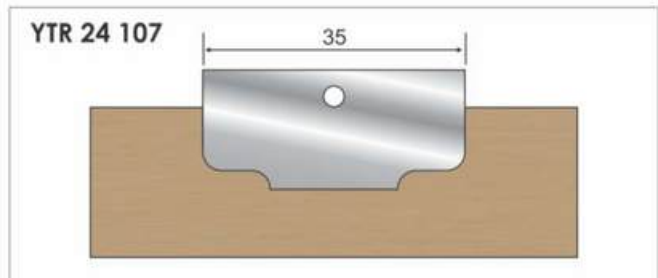
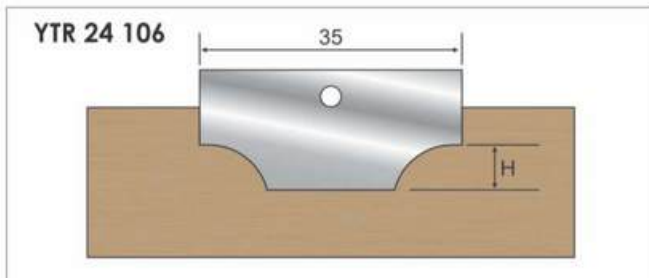





**Technical Details :**

Use on CNC Router Machine

**Application :**

Specially designed to perform difficult trimming operations, these bits are both indispensable and economical. Flush trim bits with two replaceable knives fixed by special TORX® screws. The 2-sided blades can create extra new edges.

ALSO AVAILABLE DIA 38 mm & 46mm

YTR 24					SPARE	
ORDER CODE	DIA	DEPTH	SHANK	TEETH	KNIFE	SCREW
YTR 25 101	36	4mm / 6mm / 8mm	12	2	20X 20X2	M4 X 8B
YTR 25 102	36	4mm / 6mm / 8mm	12	2	20X 20X2	M4 X 8B
YTR 25 103	36	4mm / 6mm / 8mm	12	2	20X 20X2	M4 X 8B
YTR 25 104	36	4mm / 6mm / 8mm	12	2	20X 20X2	M4 X 8B
YTR 25 105	36	4mm / 6mm / 8mm	12	2	20X 20X2	M4 X 8B

YTR 25 101

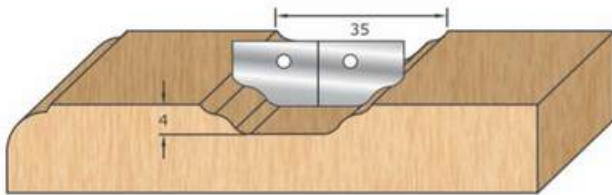

YTR 25 102

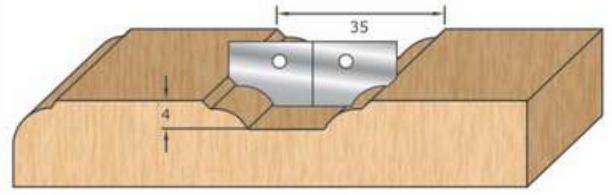

YTR 25 103

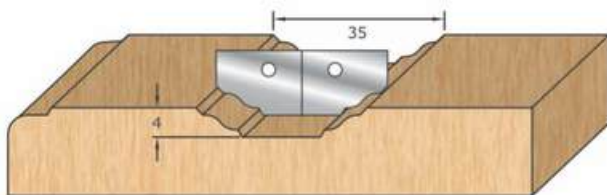

YTR 25 104

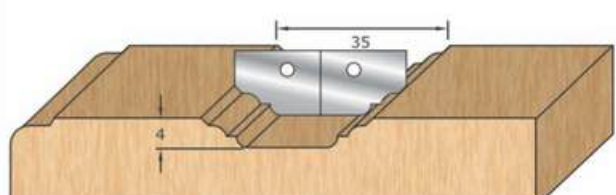

YTR 25 105

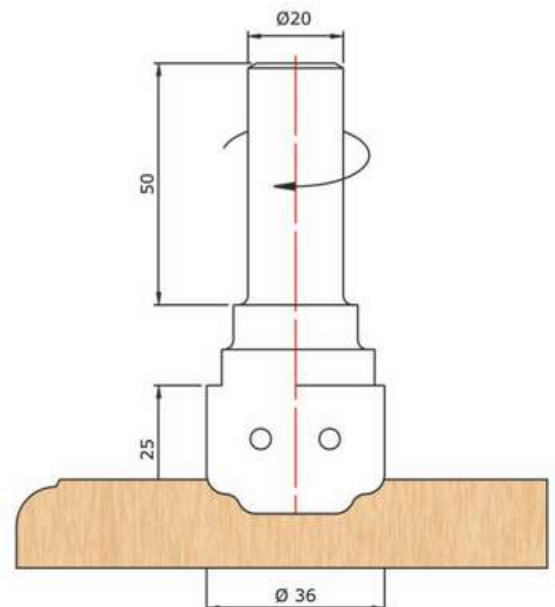
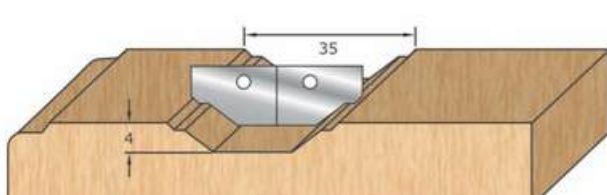

# Double Knife For Door & Chip Board ( Replaceable ) - YTR 25



### Technical Details :

Use on CNC Router Machine

### Application :

Specially designed to perform difficult trimming operations, these bits are both indispensable and economical. Flush trim bits with two replaceable knives fixed by special TORX® screws. The 2-sided blades can create extra new edges.

ALSO AVAILABLE DIA 38 mm & 46mm

YTR 25					SPARE	
ORDER CODE	DIA	DEPTH (H)	SHANK	TEETH	KNIFE	SCREW
YTR 25 106	36	4mm / 6mm / 8mm	12	2	20X 20X2	M4 X 8B
YTR 25 107	36	4mm / 6mm / 8mm	12	2	20X 20X2	M4 X 8B
YTR 25 108	36	4mm / 6mm / 8mm	12	2	20X 20X2	M4 X 8B
YTR 25 109	36	4mm / 6mm / 8mm	12	2	20X 20X2	M4 X 8B
YTR 25 110	36	4mm / 6mm / 8mm	12	2	20X 20X2	M4 X 8B
YTR 25 111	36	4mm / 6mm / 8mm	12	2	20X 20X2	M4 X 8B
YTR 25 112	36	4mm / 6mm / 8mm	12	2	20X 20X2	M4 X 8B
YTR 25 113	36	4mm / 6mm / 8mm	12	2	20X 20X2	M4 X 8B

YTR 25 106

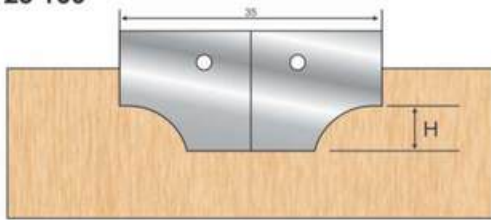

YTR 25 107

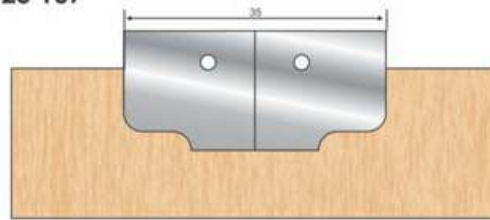

YTR 25 108

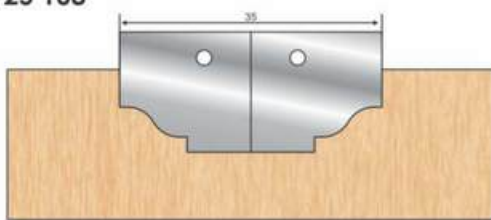

YTR 25 109

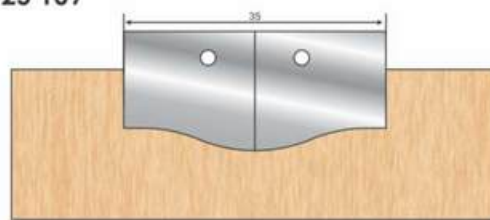

YTR 25 110

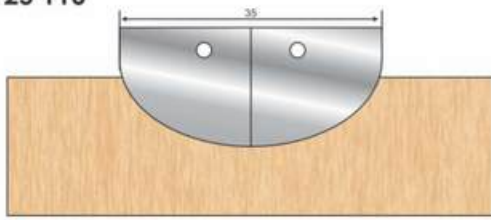

YTR 25 111

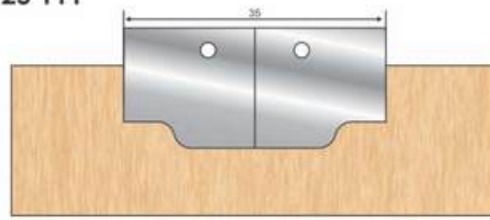

YTR 25 112

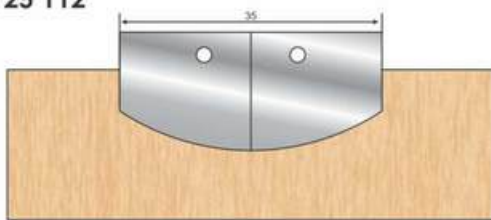

YTR 25 113

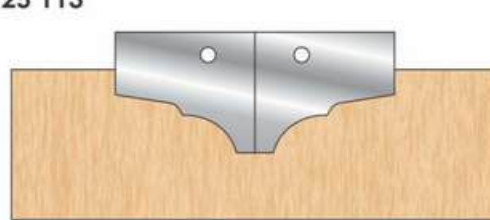



YTR 26 101



YTR 26 102



YTR 26 103

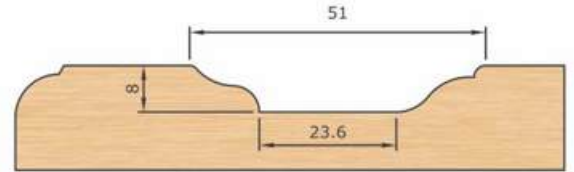

YTR 26			
ORDER CODE	DIA	SHANK	TEETH
YTR 26 101	46	12 / 20	2
YTR 26 102	36	12 / 20	2
YTR 26 103	30	12 / 20	2

**Technical Details :**

Use on CNC Router Machine

**Application :**

Specially designed to perform difficult trimming operations, these bits are both indispensable and economical. Flush trim bits with two replaceable knives fixed by special TORX® screws. The 2-sided blades can create extra new edges.

YTR 26 101

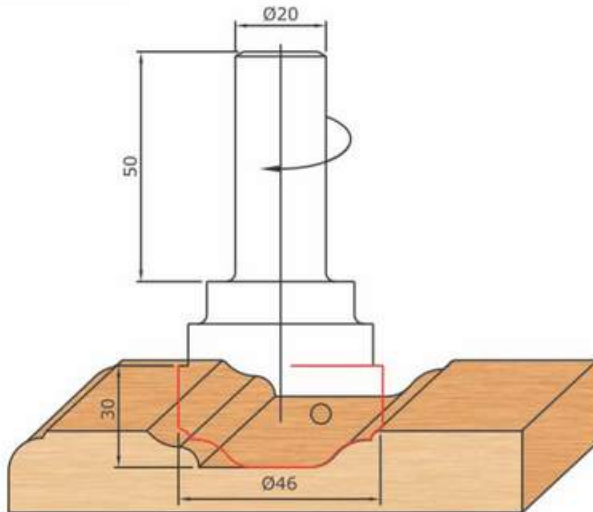

YTR 26 102

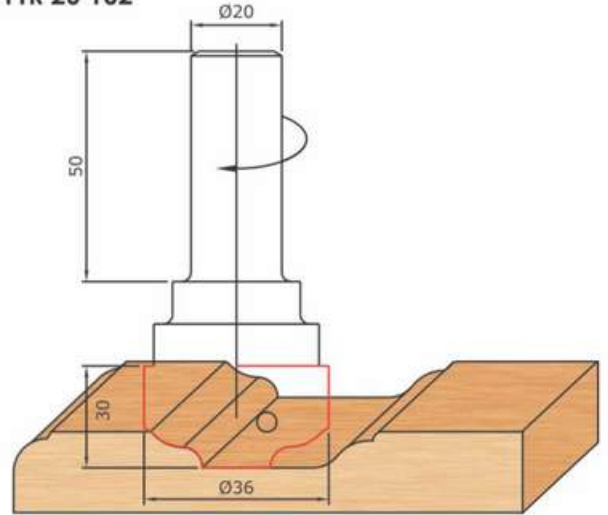

YTR 26 103

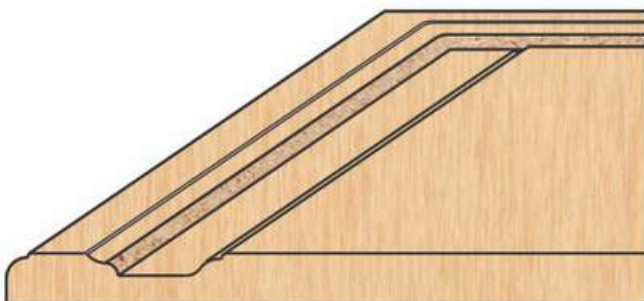
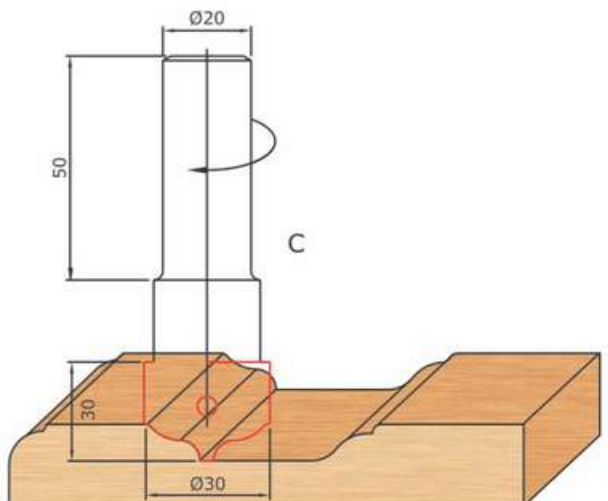

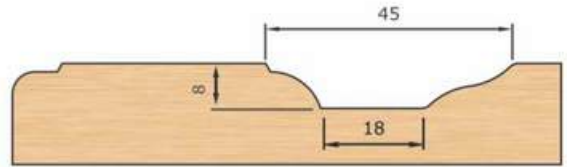

YTR 27			
ORDER CODE	DIA	SHANK	TEETH
YTR 27 101	46	12 / 20	2
YTR 27 102	36	12 / 20	2
YTR 27 103	25	12 / 20	2
YTR 27 104	20	12 / 20	2

**Technical Details :**

Use on CNC Router Machine

**Application :**

Specially designed to perform difficult trimming operations, these bits are both indispensable and economical. Flush trim bits with two replaceable knives fixed by special TORX® screws. The 2-sided blades can create extra new edges.

YTR 27 101

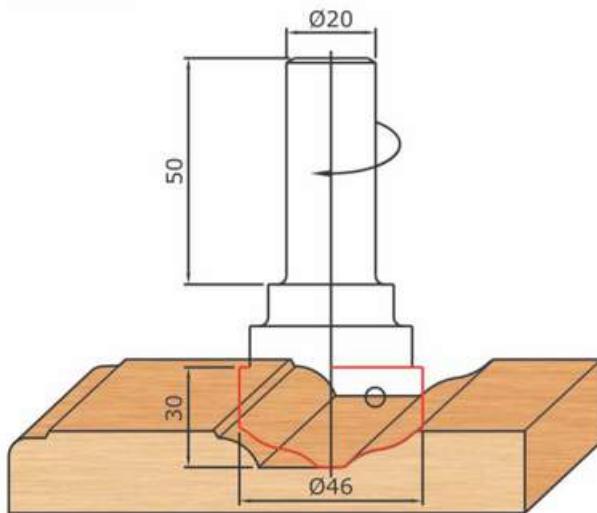

YTR 27 102

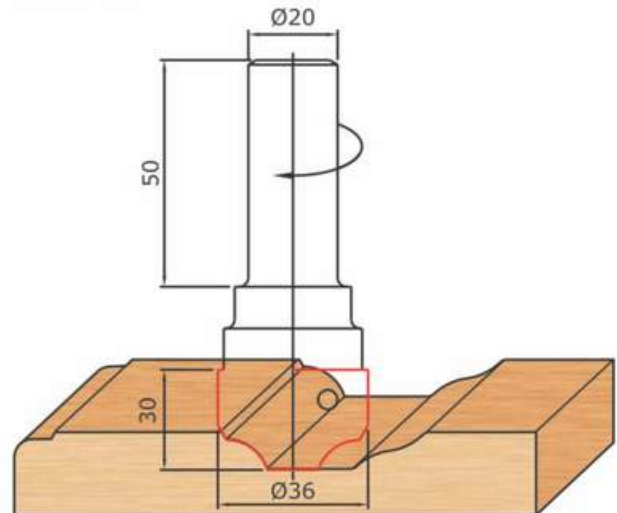

YTR 27 103

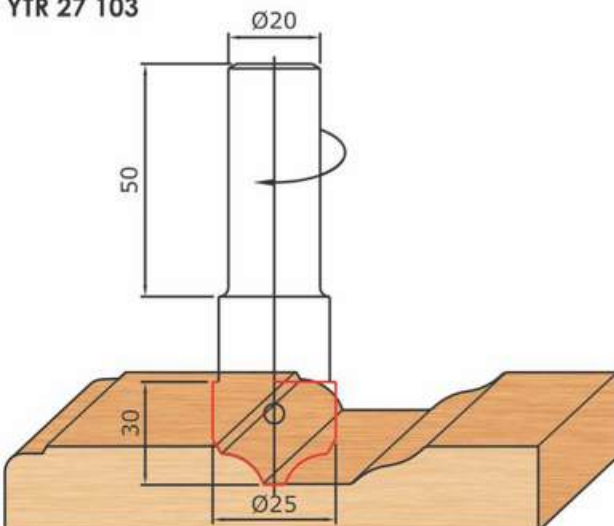

YTR 27 104

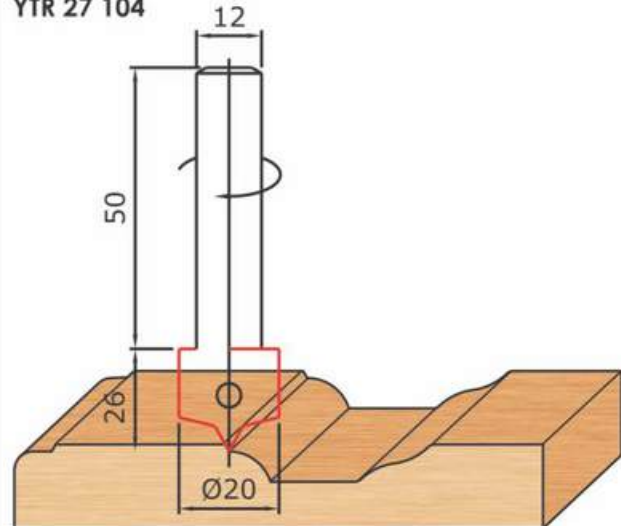



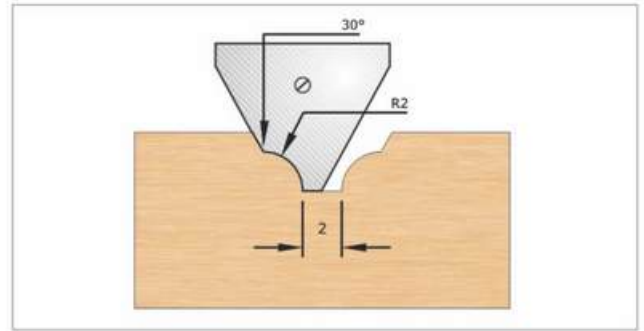
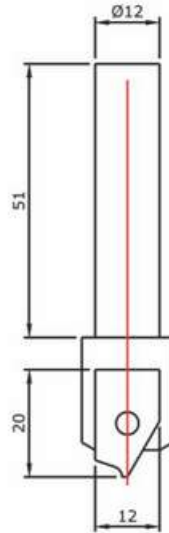

YTR 28			SPARE		
ORDER CODE	DIA	SHANK	KNIFE	SCREW	STOPPER
YTR 28 101	12	12	20 X 12 X 1.5	M4 X 5B	M5 X 8B
YTR 28 102	12	12	20 X 12 X 1.5	M4 X 5B	M5 X 8B
YTR 28 103	12	12	20 X 12 X 1.5	M4 X 5B	M5 X 8B
YTR 28 104	12	12	20 X 12 X 1.5	M4 X 5B	M5 X 8B
YTR 28 105	12	12	20 X 12 X 1.5	M4 X 5B	M5 X 8B
YTR 28 106	12	12	20 X 12 X 1.5	M4 X 5B	M5 X 8B
YTR 28 107	12	12	20 X 12 X 1.5	M4 X 5B	M5 X 8B
YTR 28 108	12	12	20 X 12 X 1.5	M4 X 5B	M5 X 8B
YTR 28 109	12	12	20 X 12 X 1.5	M4 X 5B	M5 X 8B

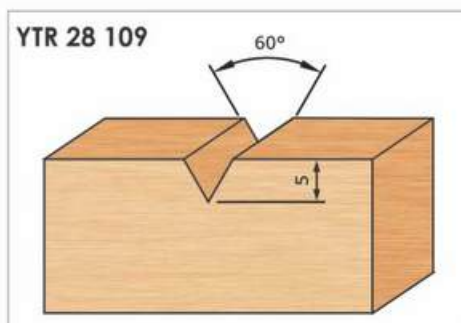
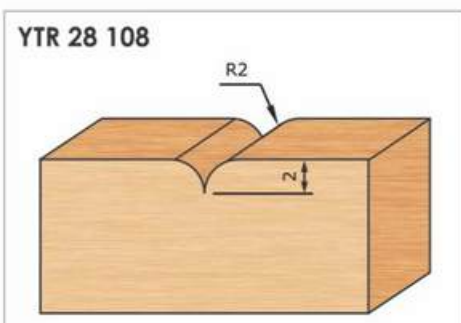
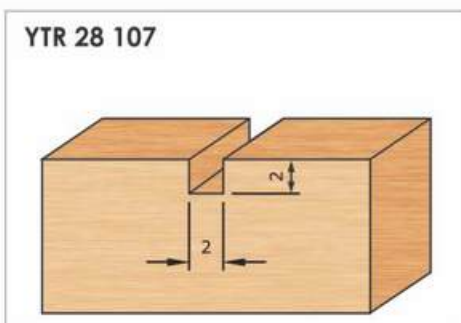
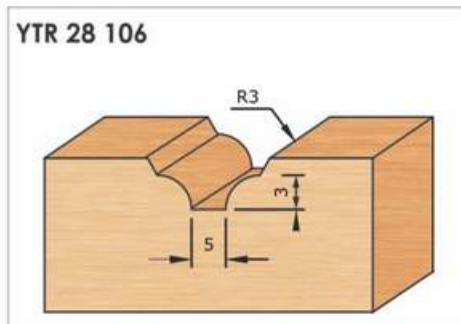
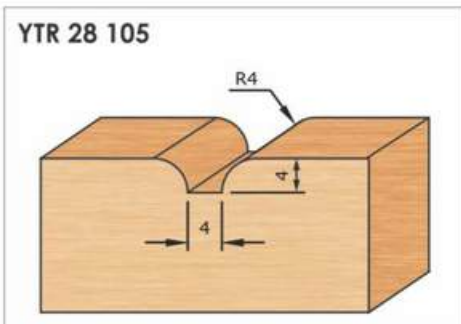
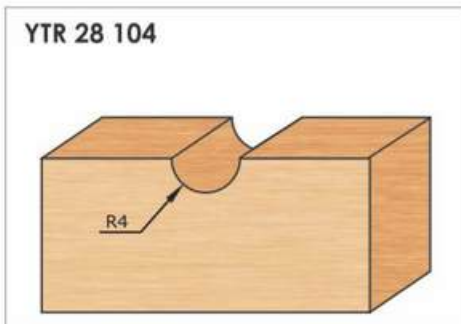
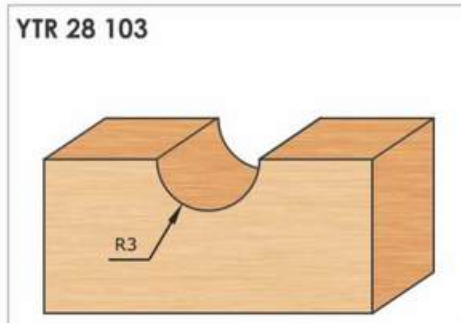
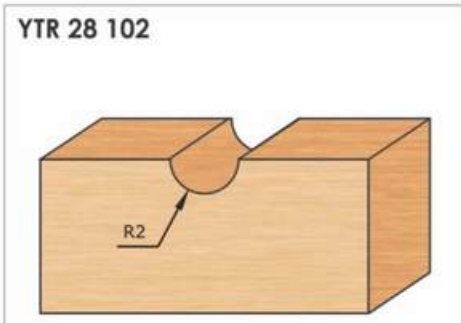
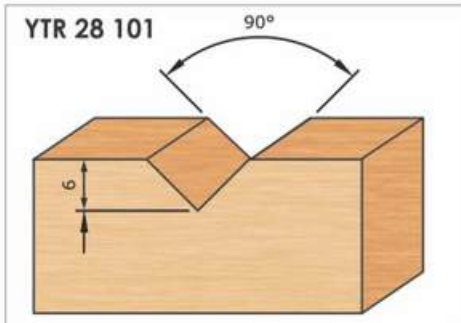



**Technical Details :**

Use on CNC Router Machine

**Application :**

Specially designed to perform difficult trimming operations, these bits are both indispensable and economical. Flush trim bits with two replaceable knives fixed by special TORX® screws. The 2-sided blades can create extra new edges.

**YTR 29**

ORDER CODE	KNIFE	SCREW	STOPPER
YTR 29	50X25X2	M4 X 5B	M5 X 8B

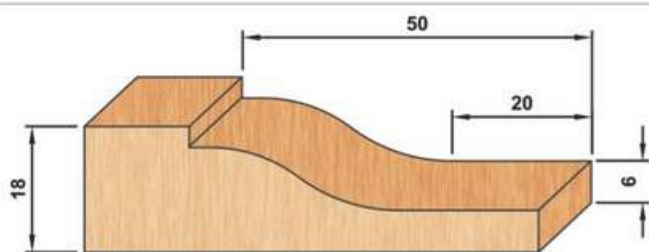

**YTR 29**

ORDER CODE	DIA	MOULDING SIZE	SHANK	TEETH
YTR 29 101	100	40 x 18	16 / 20	2
YTR 29 102	100	50 x 18	16 / 20	2

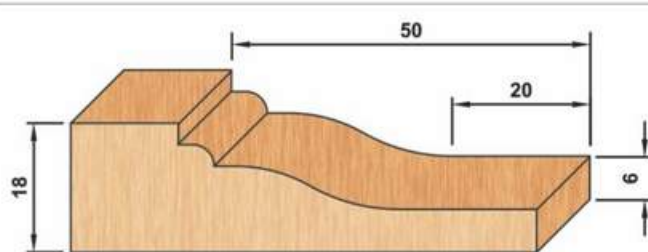

**YTR 29**

ORDER CODE	DIA	MOULDING SIZE	SHANK	TEETH
YTR 29 103	100	40 x 18	16 / 20	2
YTR 29 104	100	50 x 18	16 / 20	2

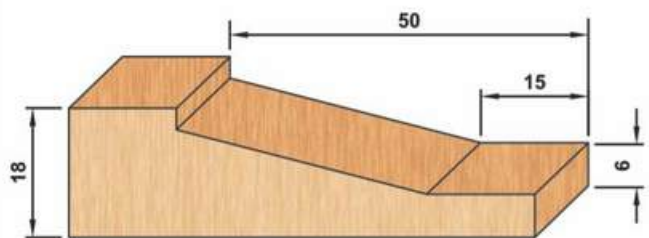

**YTR 29**

ORDER CODE	DIA	MOULDING SIZE	SHANK	TEETH
YTR 29 105	100	40 x 18	16 / 20	2
YTR 29 106	100	50 x 18	16 / 20	2

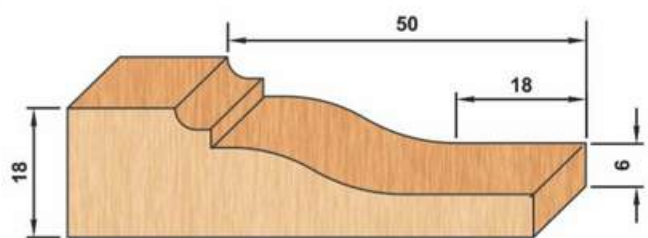

**YTR 29**

ORDER CODE	DIA	MOULDING SIZE	SHANK	TEETH
YTR 29 107	100	40 x 18	16 / 20	2
YTR 29 108	100	50 x 18	16 / 20	2

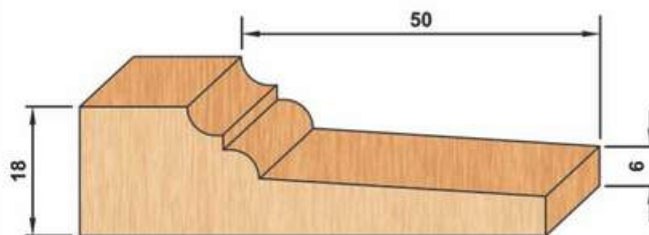

**YTR 29**

ORDER CODE	DIA	MOULDING SIZE	SHANK	TEETH
YTR 29 109	100	40 x 18	16 / 20	2
YTR 29 110	100	50 x 18	16 / 20	2

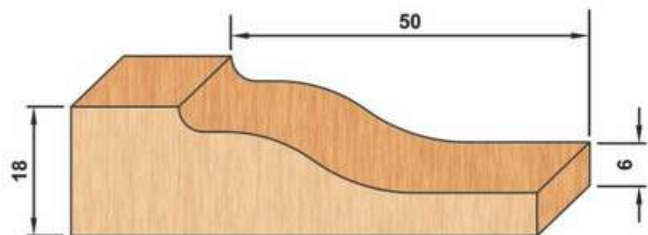

**YTR 29**

ORDER CODE	DIA	MOULDING SIZE	SHANK	TEETH
YTR 29 111	100	40 x 18	16 / 20	2
YTR 29 112	100	50 x 18	16 / 20	2



## Flush Trim Router Bit ( Replaceable ) - YTR 30



**Technical Details :**

Use on CNC Router Machine

**Application :**

Specially designed to perform difficult trimming operations, these bits are both indispensable and economical. Flush trim bits with two replaceable knives fixed by special TORX® screws. The 2-sided blades can create extra new edges.

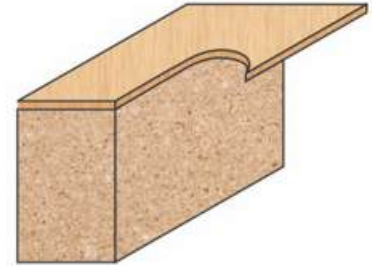

YTR 30				SPARE		
ORDER CODE	DIA	CUTTING LENGTH	SHANK	KNIFE	SCREW	BEARING
YTR 30 101	19	30	12 / 16	30 X 12 X 1.5	M4 x 5B	19mm
YTR 30 102	19	50	12 / 16	50 X 12 X 1.5	M4 x 5B	19mm

## Flush Trim Router Bit ( Replaceable ) - YTR 31



**Technical Details :**

Use on CNC Router Machine

**Application :**

Specially designed to perform difficult trimming operations, these bits are both indispensable and economical. Flush trim bits with two replaceable knives fixed by special TORX® screws. The 2-sided blades can create extra new edges.

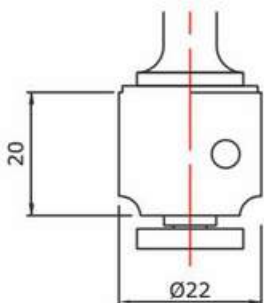
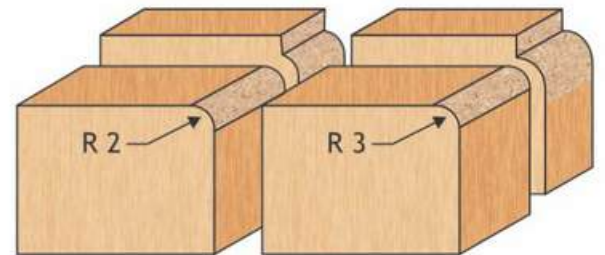

YTR 31					SPARE			
ORDER CODE	DIA	CUTTING LENGTH	RADIUS	SHANK	KNIFE	SCREW	BEARING	
YTR 31 101	22	20	2 R	12 / 16	20 X 9 X 1.5	M4 x 5B	19mm	
YTR 31 102	22	20	3 R	12 / 16	20 X 9 X 1.5	M4 x 5B	19mm	

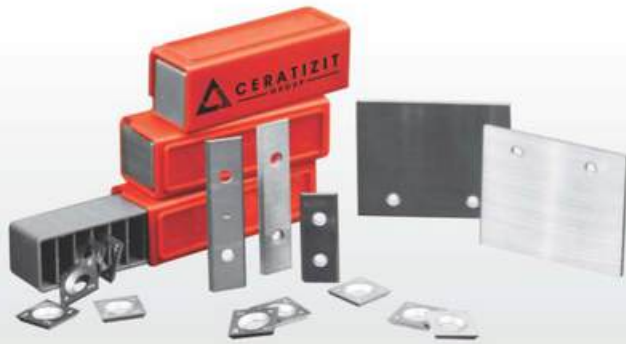

4 Cutting Edge-  
**YTR 32**

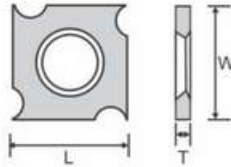

YTR 32			
ORDER CODE	L (mm)	W (mm)	T (mm)
YTR 32 101	18	18	1.95
YTR 32 102	18	18	2.95

4 Cutting Edge-  
**YTR 33**

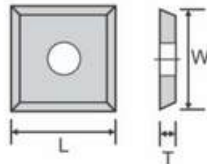

YTR 33			
ORDER CODE	L (mm)	W (mm)	T (mm)
YTR 33 101	13.8	13.8	2.5
YTR 33 102	14	14	2
YTR 33 103	14	14	2.5
YTR 33 104	15	15	2
YTR 33 105	15	15	2.5

2 Cutting Edge-  
**YTR 34**

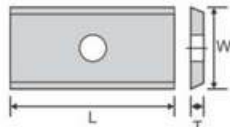

YTR 34			
ORDER CODE	L (mm)	W (mm)	T (mm)
YTR 34 101	7.5	12	1.5
YTR 34 102	9.6	12	1.5
YTR 34 103	12	12	1.5
YTR 34 104	15	12	1.5
YTR 34 105	19.2	12	1.5
YTR 34 106	20	12	1.5

2 Cutting Edge-  
**YTR 35**

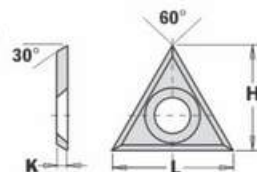

YTR 35			
ORDER CODE	L (mm)	W (mm)	T (mm)
YTR 35 101	22	19	2
YTR 35 102	22	19	2

2 Cutting Edge-  
**YTR 36**

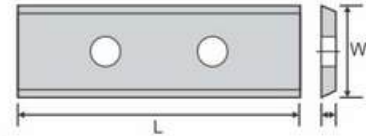

YTR 36			
ORDER CODE	L (mm)	W (mm)	T (mm)
YTR 36 101	24.2	12	1.5
YTR 36 102	30	12	1.5
YTR 36 103	40	12	1.5
YTR 36 104	50	12	1.5
YTR 36 105	60	12	1.5

4 Cutting Edge-  
**YTR 37**

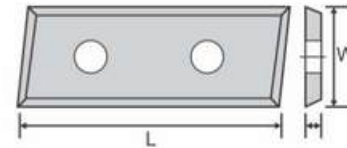

YTR 37			
ORDER CODE	L (mm)	W (mm)	T (mm)
YTR 37 101	29.5	9	1.5
YTR 37 102	29.5	12	1.5
YTR 37 103	39.5	12	1.5
YTR 37 104	49.5	12	1.5
YTR 37 105	59.5	12	1.7

4 Cutting Edge-  
**YTR 38**

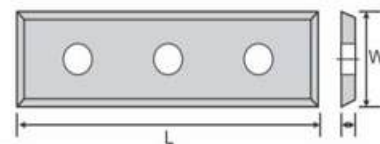

YTR 38			
ORDER CODE	L (mm)	W (mm)	T (mm)
YTR 38 101	50	12	1.7

4 Cutting Edge-  
**YTR 39**

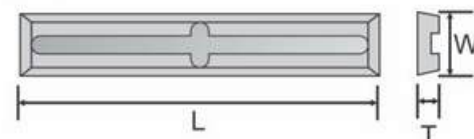

YTR 39			
ORDER CODE	L (mm)	W (mm)	T (mm)
YTR 39 101	20	4.1	1.1
YTR 39 102	20	5.5	1.1
YTR 39 103	30	5.5	1.1
YTR 39 104	50	5.5	1.1





**YTR 40**

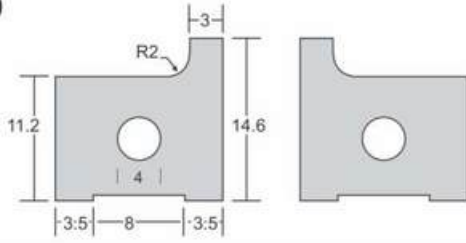

**YTR 41**

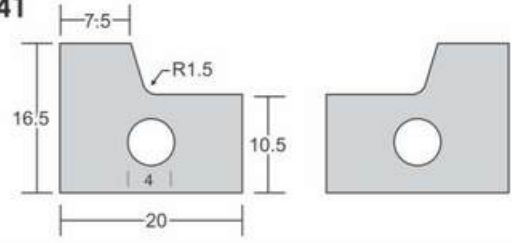

**YTR 42**

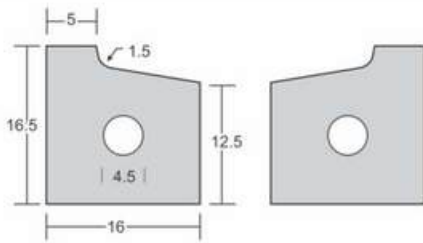

**YTR 43**

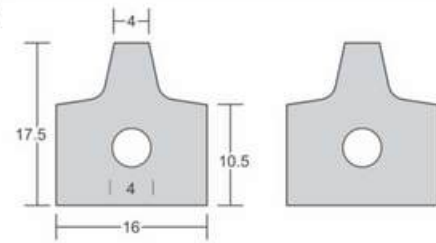

**YTR 44**

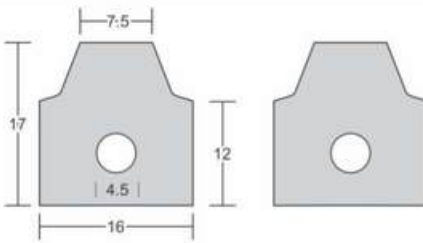

**YTR 45**

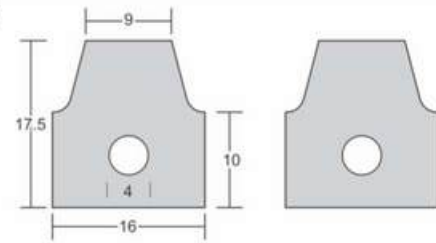

**YTR 46**

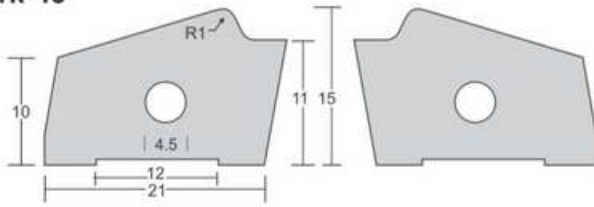

**YTR 47**

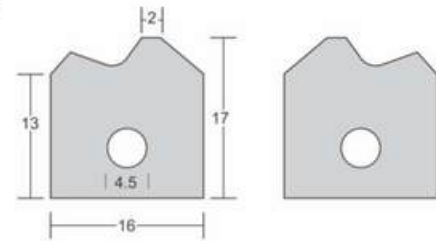

**YTR 48**

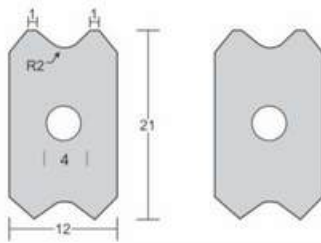

**YTR 49**

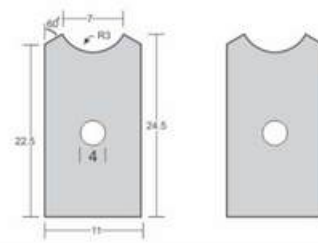

**YTR 50**

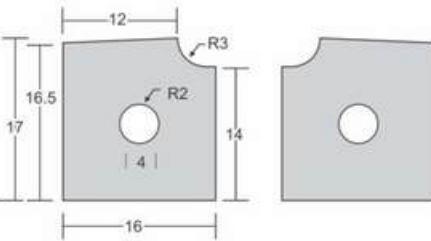

**YTR 51**

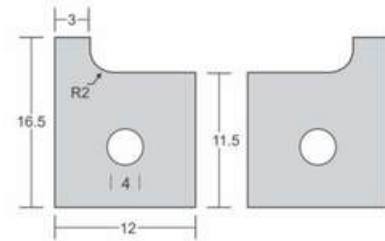

**YTR 52**

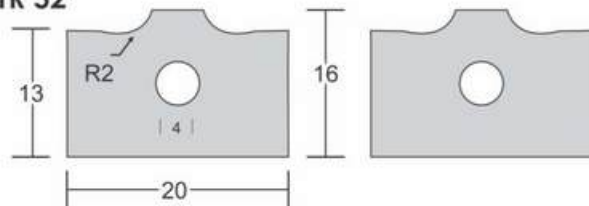

**YTR 53**

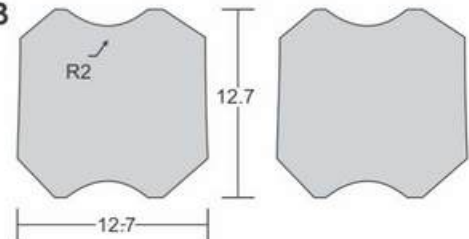

New **Technology**  
One **Quality**  
One **Name**

Next Generation Tools By



**YASH TOOLING SYSTEM**

Plot No.: 462, Road No.: 12, Kathwada G. I. D. C., Odhav, Ahmedabad – 382430, Gujarat, INDIA  
**Phone** : +91 9925430880 , 8000630880, 9925412341 **Email** : yashtoolingsystems@gmail.com